

INSTRU TECH

TECHNICALMAGAZINE

A.Y.2024-25



ICONS

Instrumentation & Control Student's Chapter

Department of Instrumentation and Control Engineering

Maratha Vidya Prasarak Samaj's

**Karmaveer Adv. Baburao Ganpatrao Thakare College of
Engineering, Nashik-422013 (India).**

Institute Vision

To be internationally accredited, Multidisciplinary, and Multi-collaborative institute working on technology enabled platform fostering innovations and patents through state-of-art academic system designed by highly qualified faculty for the development of common masses at large.

Institute Mission

To educate and train common masses through undergraduate, post graduate, research programs by inculcating the values for discipline, quality, transparency and foster career and professional development for employment thereby contributing to the development of society

Department Vision

To be an accredited department of preferred choice among common masses in the multidisciplinary field of automation and control engineering.

Department Mission

- To prepare competent professionals to meet current and future demands of industry, academia and society of multidisciplinary field of automation.
- To strengthen collaboration with reputed industries and institute of global insight.
- To inculcate spirit of research and entrepreneurship amongst the students.

Program Educational Objectives

- 1.** To build core competency in the multidisciplinary field of automation to cater the industry and research needs.
- 2.** Develop multi-disciplinary skills, team spirit and leadership qualities with ethics, to excel in professional career and higher studies in Instrumentation and Control Engineering.
- 3.** To learn and apply contemporary technologies for addressing impending challenges for the benefit of organizations and society.

Index

1. CONTROL OF X-Y TABLE USING PLC
2. AXIAL DECKING MACHINNE
3. DEVELOPMENT OF PLC BASED PNEUMATICS TRAINER KIT
4. DISPLAY AND CONTROL OF FIRE FIGHTING PANEL USING ARDUINO
5. MART ELEVATOR BY LAB VIEW
6. A PID BASED TANK MANAGEMENT SYSTEM
7. AUTOMATIC MEDICINE VENDING MACHINE
8. AUTOMATIC PELLETE LOADING MACHINE
9. AUTOMATIC SHUTTER SYSTEM USING PLC
- 10.AS AND FLAME EMERGENCY SHUTDOWN SYSTEM

1.Control of X-Y Table Using PLC

Name of Students: Pranav Sanjay Patil
Pranav Rajendra Patil
Kunal Hemant Fegade

Year: B.E. _2024-25

Title: *Control of X-Y Table Using PLC*

Abstract:

Programmable logic control (PLC) is the most common automation controller that being used in industry. It is universally applied for factory automation, process control and manufacturing systems. The system is originated from the creation of computerized versions of relay control systems which is used to control machines. There are several types or models PLC used. Ladder logic is a program method which is used to allow the sequences of logical actions to be set up, inter-linked and timed. This project being use SIMATIC S7 as a medium controller for controlling XY table education training kit. The program will be developing to control positioning axis and functioning switch and buttoning XY table. Ladder diagram (LD) and function block diagram (FBD) are chosen as program languages. There are four phase methodology of rapid application development (RAD) is applied and will be more

presses and absorbed in the methodology flow chart program to ensure the objectives are achieved. The appropriate instruction control programming of XY table will be recommended as result, then several suggestion will be recommend from the observation and analysis program developed closely to the project report.

Introduction:

1.1 Introduction of the Project Work:

There are various types of XY table being used in machine technology. The apparatus is applied in positioning element mechanism of lathe, milling and other machine. The most was applied in control numerical controller (CNC) machining center. The XY table is use for moves to work of marking, cutting, drilling and others. The named of XY table is because of the prime activity X and Y axis. Then, there is also Z axis which is for the vertical axis.

The XY table that used on the project is a just an education training kit and located to the manufacturing engineering laboratory. There is no any automated controller have been explore on it. This (manually operate) makes more weakness in controlling performance of positioning. The suitable controller with familiar and popular in the productivity industry, PLC is used as a medium improvement the system.

The program being developing to controlling the movement XY table with functioning the buttoning with

consider the bulbs and the safety regulation, then positioning the axis to the point that make with functioning the magnet to pick and place an object.

PLC offer five medium language but there are only three in Siemens PLC and the project will done two from it. There are ladder and functional block diagram. The education training kit of XY table is installing to the program software and connected to the brain module PLC called central processing unit (CPU) which is analyzing the program setup.

A PLC is a computer, having connection to external input and output. The program of a PLC has the task to set the output, depending on the input and the program. PLC diagram is performing by Boolean logic gates which are work on the equal logic equation.

The sequences of PLC working is an input accepts a variety of digital or analog signals *Rom* various field devices and converts them into a logic signal that can be used by the CPU. While the CPU responsible to make the decisions and executes control instructions based on program instructions in memory. Output modules convert control instructions from the CPU into a digital or analog signal that can be used to control various field devices for example actuators. A program device is used to input the desired instructions. These instructions will determine what the PLC will do for a specific input.

The conventional relay/ contractor control system performs all controlling processes at the same time. The program sequence is executed step by step and is repeated cyclically.

1.2 Problem Statement:

The trend toward automation of production equipment is putting great demands on people since the early of 1970s. The manufacturers have worked to increase productivity, capability, reliability, and flexibility by using technologies. In order to achieve these are making use more and more automation in manufacturing. PLC is one of the solutions.

The positioning element mechanism numerically controlled XY table using manually is quietly popularly. Toward the project, although in just an education training kit its will applies controller system as same as a truly machine. These of developing program considering to the precaution rule as same in the machine production operation.

1.3 Objectives:

By according to the title, the objectives of this project are:

- To recommend new program system to control the positioning axis and functioning button of XY table.
- To develop new program to control the positioning axis and functioning button of XY table

1.4 Scope of Project:

The aim of this project is to develop a new program that will control the positioning of the X and Y axes. At this stage, it is important to recognize all the essential components involved in the system. The scope of this project consists of three main parts: the XY table, the PLC, and the overall control mechanism. The XY table serves as the primary platform for movement, allowing precise positioning along both axes. The PLC plays a crucial role in generating control signals, processing inputs, and executing programmed instructions to achieve accurate motion control. Additionally, the system will be designed to enhance automation, improve accuracy, and ensure smooth operation. Through this project, a structured approach will be taken to develop a reliable and efficient positioning control system that can be implemented for various industrial applications.

1.4.1 XY Table:

- Learn the basic operation.
- Investigate the structure of input and output (switches button and components) and their address.

1.4.2 PLC :

- Analyze the features and identify the components on PLC program.
- Investigate and describe the function of each device such as the counter and relay.
- Study ladder diagram and function block diagram program structure and learn how to program then minimize the program language to be a simple network program.

- Investigate the address uses and develop new program regarding to both mode control.
- Develop the new program which positioning the axis with magnet pick and place an object to the point making.



Figure 1.2: Original Setup of X-Y table

1.5 Project Flow Chart

The flowchart of this project follows a systematic approach, starting from initialization and progressing through various stages to achieve precise XY positioning control. The process begins with the **system initialization**, where the PLC is powered on, and the initial parameters such as home position, speed, and movement limits are set. Once the system is initialized, the **input signals** from sensors, limit switches, or user commands are received and processed by the PLC. These inputs determine the required motion of the XY table.

Next, based on the received inputs, the **PLC processes the control logic** by executing the programmed instructions. This includes calculating the required displacement, determining the movement direction, and ensuring safety conditions before sending output signals. After processing the logic, the **PLC sends control signals to actuators or motor drivers**, enabling

the movement of the XY table along the X and Y axes as per the required position.

During movement, **feedback from encoders or sensors** is continuously monitored to ensure precise positioning. If any deviation or error is detected, the system adjusts the movement accordingly to maintain accuracy. Once the desired position is reached, the **system confirms the completion of movement**, and the process either stops or loops back if another movement command is received.

Finally, the system checks for any **errors or faults**, such as overtravel, motor failure, or communication issues. If an error is detected, an alarm is triggered, and corrective action is taken before proceeding. If no issues are found, the system continues its operation smoothly. This structured approach ensures reliable, efficient, and automated control of the XY positioning system.

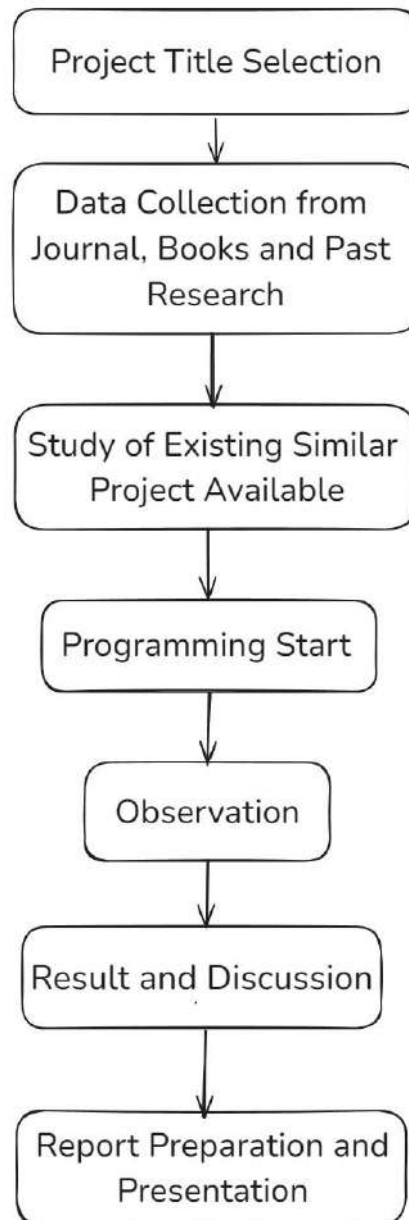

Figure 1.3: Project Flow Chart

1.5.1 Project Summary

For ease to read and comprehension, this project report is written by following or according the arrangement of chapter which has been decided. There are six chapters in this report which each of them consist different explanation according to the chapter. one is about the introduction of the project.

This chapter explains and contains the introduction of this project which include the research and the objective of why this research is done.

Chapter two is literature review. The purpose of this chapter is to explain and to clarify the theoretical and information that interconnected, applied research and past research.

Chapter three is the methodology strategy that has been used to complete this project. S7 PLC is as the medium of automation programming software. The programming is done by two types of languages which are the ladder diagram and functional block diagram.

Chapter four is the research results. This chapter will explain and describe what are the achievements of this project and will tell whether this research achieve the project objectives.

Chapter five is discussion which concludes the overall of this project especially the results of what have been achieved from this research. From the observation, the chapter will clarify the problem and realization.

Chapter six contains the summary and conclusion of this project. This chapter may contain or brief the summary of the entire work, method, results, and recommendation arising from the research.

LITERATURE REVIEW

2.1 Introduction:

This chapter will introduce the theoretical of XY table, PLC and Siemens PLC. The mechanism of numerical control XY table touches to the components and the control system which is as guidance to the system function. The section will describe differential between point-to-point and

continuous path control method, loop system, and positioning coordinate system. The program of Siemens PLC describes and identifies the hardware and internal architecture. Then the chapter will introduce to the program structure of LD and FBD.

2.1.1 XY Table:

XY table is one of numerical control (NC) categorize. Numerical control is the operation of table axis by a series of coded instructions consisting of numbers, letters of the alphabet, any symbols that the machine control unit (MCU) can be understand (Khar, S. *et al.* 2000). These instructions are converted into electrical pulses of current that the table motors and controls follow to carry out the operation. The numbers, letters, and symbols are coded instruction that refer to specific distances, position, function, or motions, which the axis can understand as it on operation work. XY table is being used on all types of machine tools, from the simplest to the most complex. The most common machine tools are single-spindle drilling machines, lathes, milling machine, turning centers, and machining centers. The X axis controls the cross motion. The Y axis controls toward or away from the column. The Z axis controls the vertical (up and or down) movement

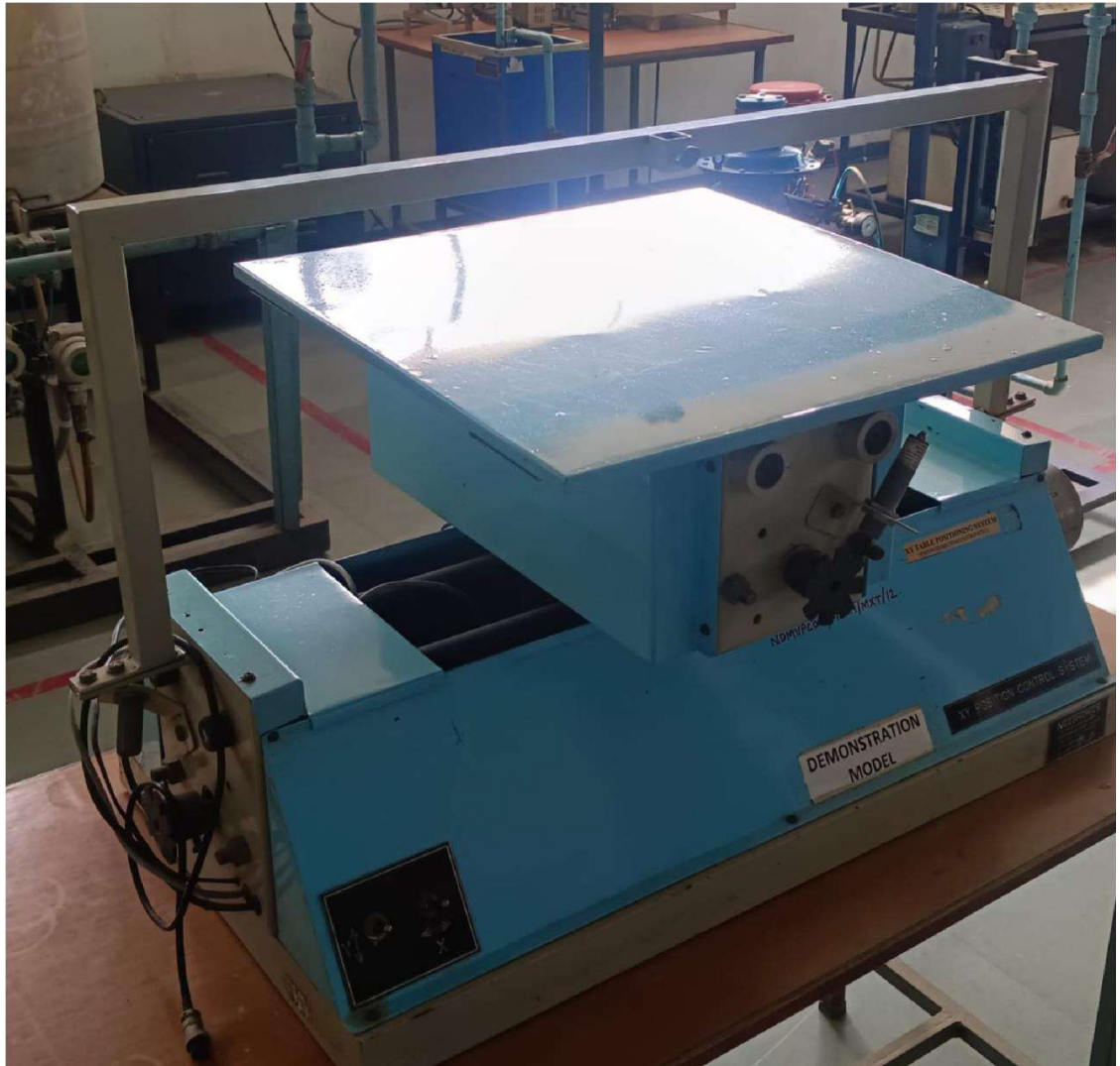

Figure 2.1: Control of X-Y table using PLC

2.1.2 Component Mechanisms:

The built-up XY table motion mechanism is include to the input and output structure. Input is devices that are use to read the instruction given, for example encoder whiles the output is devices executed of instruction such as an actuator. All of these are components to the

apparatus which are classified by two, mechanical and electrical components.

2.1.3 Mechanical Components:

The hardware of XY table includes various components such as motor, bracket, based part for table, supporting screw, sliding road, lead screw, bearing, encoder and limit switch. All of the components should be assemble correctly to ensure the functional and the traveling movement is in good condition. The part assembly is a process of each component to complete the XY table features. The assembly process includes all the variety mechanical components such as:

(a) Motor

Motor is a device covert fluid power into mechanical force and motion. It's also known as the machine that converts electrical energy into mechanical energy. Motor is a very simple and straight forward conversion movement and usually provides rotary mechanical motion. The function motor in XY table is to make the movement of the axis on the table.

Motors are located to each of the axis, and there are two types motor used in motion mechanism such servo motor and stepper motor (Asfahl, C.R. 1992). In applying to the XY table, servo motor is

first chosen compare to the stepper motor, this is courses by robustness in precise motion (Pan, J. *et al.* 2000). While AC servo motor were used by Hyuk, L. *et al.* 2000. In their research, a Saeil TNV-40 vertical CNC machining center was used for the experiments. The XY table is linked to AC servo motors which are driven by a servo pack in velocity command mode, through a ball screw with 10" pitch. Figure 2.2 shows the positioning system on CNC machining center setup.

(b) Brackets

Bracket is the joining parts between a lead screw or ball screw and the motor. The materials that have been chosen in manufacturing the bracket are mild steel. There are four holes in the brackets. Two holes are used to support the motor and another two holes are used as supporting screw.

(c) Supporting screws

Supporting screw is uses to connect the to other part. Another function is to reduce a vibration when the table was moved (Abdul Rahman, M.H. 2005).

(d) Bearing

Bearing is use to support a load while permitting relative motion between two element axis

(Mott, R.L. 2004). The term rolling bearings refers to the wide variety of bearings that use spherical ball or some other type of roller between the stationary and the moving elements. The most common type of bearing supports a rotating shaft, resisting purely radial loads or a combination of radial and axial (thrust) load. Most bearing are used in application rotation, but some are used in linear motion application.

(e) Sliding rod

Sliding rod is an actuator to the axis movement. Its can be easily to moving in horizontally and vertically. Sliding rod act as a guider and supported for surface table can travel along this part easily. Supported screw will apply to hole a sliding rod and reduce a vibration (Abdul Rahman, M.H. 2005). Sliding rod is one of the critical paths in XY table which ensure the accuracy of traveling in good condition.

(f) Proximity Sensor

A proximity sensor is a type of sensor that detects the presence or absence of an object without making physical contact. It works by emitting electromagnetic fields or a beam of radiation, such as infrared, and monitoring changes in the return signal. When an object enters the sensor's range, the signal is interrupted, allowing the sensor to detect the

object. There are several types of proximity sensors, including inductive, capacitive, ultrasonic, and photoelectric. Inductive sensors are used for detecting metal objects, while capacitive sensors can detect both metallic and non-metallic objects. Ultrasonic proximity sensors use sound waves and can detect objects regardless of their material, while photoelectric sensors use light beams to detect objects. Proximity sensors are commonly used in industrial automation, robotics, security systems, and consumer electronics due to their ability to operate without contact, making them durable and reliable in harsh environments. The detection range of proximity sensors varies based on their type and design, ranging from a few millimeters to several meters.

(g)Limit switch

A limit switch is an electromechanical device. It's used as stopper to the axis on over limit movement. A part of the limit switch, called an *actuator*, is placed in the path of an oncoming object, such as a box on a conveyor. When the object contacts the actuator, the contacts in the limit switch are opened (or closed, depending on the limit switch's design) to stop (or start) the flow of current in the electrical circuit

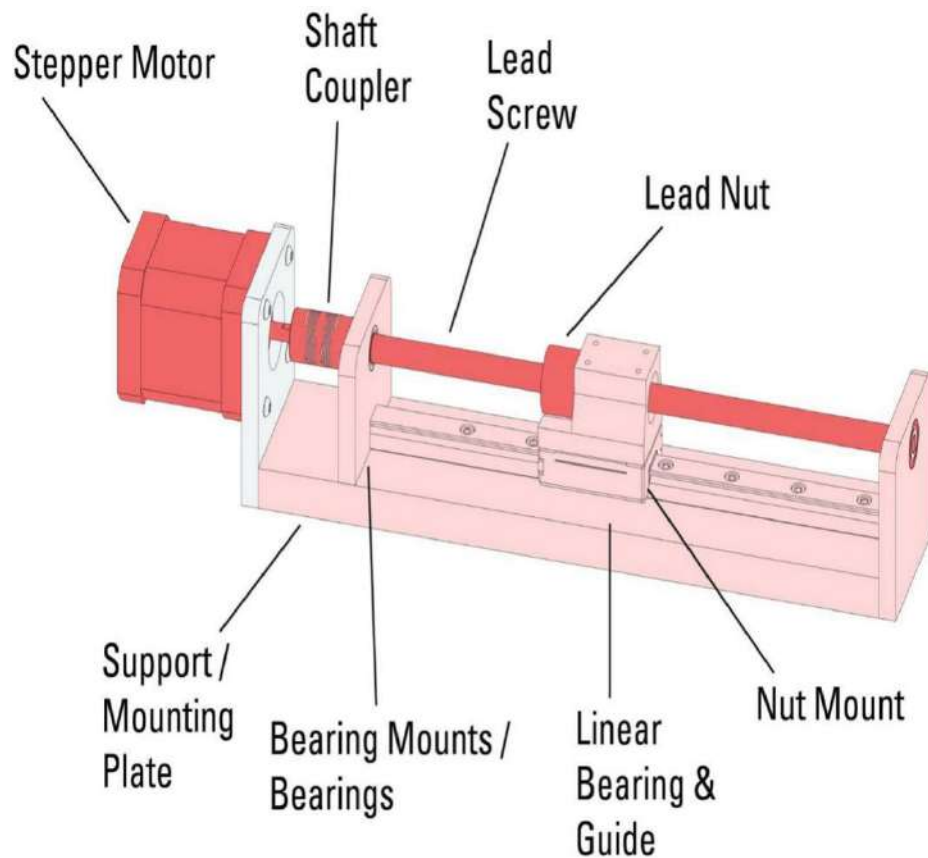

Figure 2.3: XY Table Mechanical Components

2.1.3 Electrical Components:

Motors are also an electrical component category which moves the table axis when the power electrical haven energized. The situation also occurs to limit switch and encoder which is more recognize as an electromechanically components.

Beside that an electrical component to the XY table is components to the PLC program. Electrical components control systems were mainly composed of relays and switches. Although switches are well known devices, that may not be the case for relays. Two devices contact to relay are timer and counter.

(a) Relays contacts

A relay is an electromagnetic device composed of a frame/ core, an electromagnetic coil, and contacts. A simplified, cutaway (cross section) drawing of a relay with one contact is shown in Figure 2.4

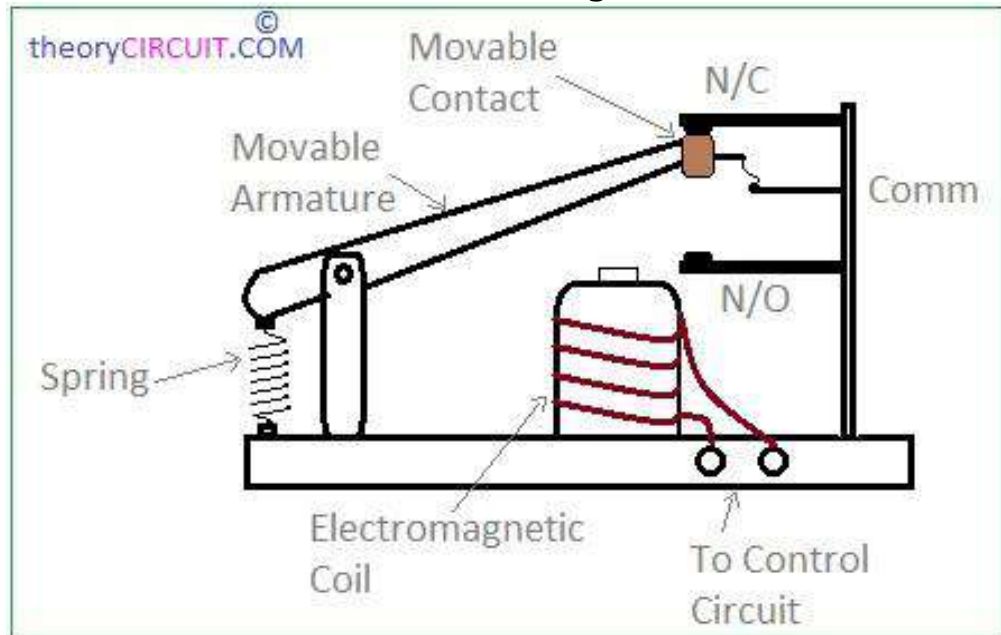

Figure 2.4: Relay Diagram

Relay contacts are electrical switches that control the flow of current in a circuit. They operate by using an electromagnet to open or close the contacts, depending on the relay's design. There are two main types of relay contacts: Normally Open (NO) and Normally Closed (NC). In an NO relay, the contacts are open when the relay is de-energized, meaning no current flows. When the relay is energized, the contacts close, allowing current to flow. In an NC relay, the contacts are closed when deenergized and open when energized.

Relays can have multiple sets of contacts, such as Single-Pole Single-Throw (SPST), Single-Pole Double-Throw (SPDT), Double-Pole Double-Throw (DPDT), depending on the application. Relay contacts are widely

used in automation, control systems, and motor control, providing isolation between the control signal and the high-power devices. Relays offer flexibility, allowing low-power circuits to control high-power devices safely.

(b) Timers

Timers are devices that count increments of time. Timers are represented by boxes in ladder logic. When a timer receives an enable, the timer starts to time. The timer compares its current time with the preset time. The output of the timer is logic 0 as long as the current time is less than the preset time. When the current time is greater than the preset time the timer output is logic 1. There are three types of timers which are on- delay (TON), retentive on-delay (TONR), and off-delay (TOF).

Timers used with PLC can be compared to timing circuits used in hardwired control line diagrams. In the following example, a normally open (NO) switch (S1) is used with a timer (TRI). For this example the timer has been set for 5 seconds. When S1 is closed, TRI begins timing. When 5 seconds have elapsed, TRI will close its associated normally open TR1 contacts, illuminating pilot light PU. When S1 is open, de-energizing TRI, the TRI contacts open, immediately extinguishing PU. This type of timer is referred to as ON delay. ON delay indicates that once a timer receives an enable signal, a predetermined amount of time (set by the timer) must pass before the timer's contacts change state.

(c) Counter

Counters used in PLC serve the same function as mechanical counters. Counters compare an accumulated value to a preset value to control circuit functions. Control applications that commonly use counters include the following.

- Count to a preset value and cause an event to occur
- Cause an event to occur until the count reaches a preset value

Counters are represented by boxes in ladder logic. Counters increment/decrement one count each time the input transitions from off (logic 0) to on (logic 1). The counters are reset when a RESET instruction is executed. Three types of counters which are up counter (CTU), downcounter (CTD), and up/down counter (CTUD).

2.1.4 Control System:

A control system is a device or set of devices to manage, command, direct or regulate the behavior of other devices or systems. The other definition control system is as an interconnection of components forming a system configuration that will provide a desired system response. Control system is a guidance of Numerical control XY table functional and it's actually convergent to the device motor uses. Control system is used to control some internal and external physical variable. The external physical numerical control system is the motion mechanism and internal is loop system. There are two common classes of control systems, with many variations and combinations. There is logic or sequential controls, and feedback or linear controls.

2.1.6 Motion Mechanisms:

There are two types control system of fundamental motion tasks used in modern mechanical of XY table numerical control systems. The types are point-to-point system (PTP) and continuous-path system (CP).

Many of the early machines table was point-to-point system. Point-to-point emphasizes product over process. It is now very important that follow the prescribed path to the finish line or will be disqualified. This would equate to operations outside of a piece are manufacturing, when the tool must follow an exact path. This process is called continuous-path system (CP). Obviously, it is more difficult to control an exact path (Stenerson, I & Curren, K. 2007). So the table of today uses the CP system. Below shows the differential and describing the both of method ways.

(a)PTP (point-to-point system)

PTP is use for the movement from one position point to another position in straight line. PTP control the positioning accuracy and the transition time is the most important features on it.

In making angles and arc point, an axis is move and all affected drive motors run at the same speed. When one axis motor has moved the instructed amount, it stops while the other motor continues until its axis reached its programmed location.

(b)CP (continuous-path system)

CP is the movement for moving along a prescribed position trajectory (tracking). It will control the transient path error when moving along the desired path which is added as a main control objective (Hace, A. *et al.* 1998). CP has the ability to move the drive motors at varying rates of speed while positioning the machine. This gives an easily accomplishment in arc and angles segments.

APPLICATIONS:

The control of X-Y tables using Siemens PLCs, as outlined in the provided document, finds broad application across various industries. X-Y tables are crucial in manufacturing and machining processes where precise movement along the X and Y axes is required. By integrating Siemens PLCs, particularly the SIMATIC S7, this project offers enhanced automation and control capabilities for the X-Y table, which are commonly used in CNC machines for cutting, drilling, milling, and other automated manufacturing tasks. education and training environments, such as engineering laboratories, X-Y table kits controlled by PLCs help students gain practical experience in understanding control systems and automation principles. The integration of ladder logic and function block diagrams in Siemens PLC

programming allows users to experiment with different automation scenarios, providing an excellent learning platform for control systems, programming languages, and motor control strategies. Additionally, industries like electronics manufacturing, automotive, and aerospace extensively use X-Y tables in automated inspection systems, where precision positioning and object manipulation are vital. The ability to program such systems through PLCs ensures reliable, repeatable operations, improving efficiency and reducing human intervention in complex tasks.

FUTURE SCOPE:

The future scope of using Siemens PLCs for X-Y table control is vast. As industries continue to evolve toward Industry 4.0 and the Industrial Internet of Things (IIoT), the demand for smarter, interconnected, and more autonomous control systems will increase. Siemens PLC systems can be enhanced with advanced features like:

1. **Integration with AI and Machine Learning:**
Future developments may include integrating artificial intelligence to optimize the X-Y table's performance, predicting maintenance needs, and automating decisionmaking processes for complex tasks.

2. **Remote Monitoring and Control:** The integration of PLCs with cloudbased systems will allow remote monitoring and diagnostics, reducing downtime and allowing for quicker interventions in case of system failures or required adjustments.
3. **Advanced Sensing and Feedback:** Improved sensors, such as highprecision encoders and limit switches, coupled with Siemens PLCs, could enable more accurate positioning, ensuring higher precision in tasks that demand tight tolerances, like semiconductor manufacturing or medical device production.
4. **Interconnected Systems:** With the rise of smart factories, Siemens PLCs will play a pivotal role in creating interconnected systems where various machines communicate and work in harmony. .

CONCLUSION:

The control of X-Y tables using Siemens PLC, specifically the SIMATIC S7, presents a significant advancement in automation for industrial and educational applications. This project demonstrates how Siemens PLCs can be employed to enhance precision and control over mechanical systems, contributing to more efficient manufacturing processes and providing a robust platform for educational training. With the ongoing development of automation technologies, the integration of Siemens PLCs into X-Y table control systems has immense potential for growth.

REFERENCES:

1. Khar S. et al. (2000). Numerical control system of XY table in modern manufacturing.
2. Hace A. et al. (1998). Belt-driven servo mechanism and motor control systems in automation.
3. Seames W.S. (2002). Point-to-point and continuous-path systems in machine control.
4. Stenerson I., Curren K. (2007). Closed-loop vs. open-loop systems in industrial automation.
5. Abdul Rahman M.H. (2005). Mechanisms of sliding rods and lead screws in XY table systems

2. AXIAL DECKING MACHINNE

Name of Students: Divya Sandip Dalal
Neha Ajay Saraf
Disha Nitin Ahire

Year: B.E. _2024-25

Title: Axial Decking Machine

ABSTRCT:

The axial decking machine is a specialized tool designed for the efficient installation of decking materials in various construction applications. By employing an axial movement mechanism, this machine facilitates precise alignment and placement of decking boards, whether they are made of wood, composite, or metal. Its robust construction ensures stability and durability, making it suitable for both residential and commercial projects.

This machine enhances productivity by automating the decking process, significantly reducing labour time and minimizing the potential for human error. Equipped with advanced technology, the axial decking machine delivers high precision in cuts and placements, which helps to reduce material waste and improve the overall quality of the installation. Additionally, modern models are designed with safety features to protect operators and ensure compliance with industry standards. Overall, the axial decking machine represents a significant innovation in the decking installation process.

Combining efficiency, accuracy, and safety for optimal performance in the construction industry. The axial decking machine ensures high precision in cuts and placements, minimizing material waste and improving the overall quality of installations. Additionally, modern models incorporate safety features to protect operators and comply with industry standards. Overall, the axial decking machine represents a significant advancement in decking installation, offering efficiency, accuracy, and safety in construction practices.

INTRODUCTION :

1. Introduction of the Project Work

The axial decking machine is a cutting-edge piece of equipment specifically engineered for the efficient installation of decking materials in various construction and manufacturing environments. As the demand for high-quality outdoor and indoor decking solutions continues to grow, this machine has emerged as a vital tool for contractors and builders seeking to enhance productivity and precision in their projects.

At its core, the axial decking machine operates on the principle of axial movement, which allows for the accurate alignment and placement of decking boards. This mechanism is

particularly beneficial for handling a wide range of materials, including traditional wood, composite materials, and metal decking. The machine's design typically features a robust frame that provides stability during operation, ensuring that the decking is installed uniformly and securely.

One of the primary advantages of the axial decking machine is its ability to automate the decking installation process. By reducing the reliance on manual labour, the machine not only speeds up project timelines but also minimizes the risk of human error, leading to higher quality outcomes. The precision offered by the machine results in cleaner cuts and more accurate placements, which ultimately reduces material waste and enhances the overall aesthetic of the finished product.

In addition to its operational efficiency, modern axial decking machines are equipped with advanced safety features to protect operators and ensure compliance with industry regulations. These features may include emergency stop buttons, safety guards, and userfriendly controls that enhance the overall safety of the work environment.

Overall, the axial decking machine represents a significant advancement in decking installation technology. Its combination of efficiency, precision, and safety makes it an invaluable asset for construction professionals looking to meet the increasing demands of the market while maintaining high standards of quality in their work. As the construction industry continues to evolve, the axial decking machine is poised to play a crucial role in shaping the future of decking installation practices.

1.2 Objectives

- i) **Increased Efficiency:** The machine aims to streamline the decking installation process, significantly reducing the time required to complete projects. By automating various aspects of the installation, it minimizes manual labour and accelerates workflow.

- ii) **Precision and Accuracy:** One of the main goals is to ensure high levels of precision in the alignment and placement of decking materials. This reduces the likelihood of errors, resulting in cleaner cuts and a more aesthetically pleasing final product.
- iii) **Material Optimization:** The axial decking machine is designed to minimize waste by ensuring accurate measurements and cuts. This objective helps in reducing material costs and promoting sustainable practices in construction.
- iv) **Versatility:** The machine aims to accommodate a wide range of decking materials, including wood, composite, and metal, making it suitable for various applications in both residential and commercial projects.
- v) **Safety Enhancement:** A critical objective is to incorporate safety features that protect operators and ensure compliance with industry standards. This includes emergency stop mechanisms, safety guards, and user-friendly controls to create a safer working environment.
- vi) **Quality Improvement:** By providing consistent and reliable performance, the axial decking machine contributes to the overall quality of decking installations, ensuring that they meet or exceed industry standards.
- vii) **Cost-Effectiveness:** Ultimately, the machine aims to reduce labour costs and project timelines, making decking installation more cost-effective for contractors and builders.

LITERATURE REVIEW:

The demand for efficient, high-quality decking installations in construction projects has led to the development of automated machinery such as the axial decking machine. This section reviews the existing literature on decking machines, axial motion technologies, and advancements in automated construction systems.

1. Automation in Construction:

The adoption of automation in construction has significantly increased over the past decade, with machines being developed to reduce human labour, improve precision, and shorten project timelines. Automated decking machines are part of this broader trend of construction automation, enabling more efficient processes for repetitive and labour-intensive tasks. According to Skibniewski (1992), automation enhances not only productivity but also safety and quality in construction projects by minimizing manual interventions in hazardous or precision-critical tasks. In recent years, robots and automated systems have seen increased use in various construction applications such as bricklaying, welding, and concrete pouring (Sawhney 2020). These machines provide greater accuracy and reduce material wastage, which is increasingly important in sustainable construction practices. The axial decking machine is part of this growing movement, offering automation to the decking installation process.

2. Axial Movement Technology: Axial movement refers to motion along a straight line, typically guided by precision mechanisms such as ball screws, linear actuators, or pneumatic systems (Grover, 2016). Machines utilizing axial movement have shown great promise in industries requiring high levels of precision, including CNC machining and assembly line robotics (Yusuf & Hashmi, 2010). The axial decking machine leverages this technology to align and install decking materials accurately, ensuring uniformity and consistency in placement. The precision and stability offered by axial movement technology make it ideal for tasks that involve repetitive motion and tight tolerances. In decking installation, this precision translates to cleaner cuts, better alignment of decking boards, and reduced waste of materials such as wood, composites, or metal.

2. Advancements in Decking Materials: The choice of decking materials has evolved significantly, with traditional timber now complemented by composite materials, metals, and other engineered options. Wood remains a popular choice due to its aesthetic appeal, while composite materials offer improved durability and lower maintenance (Smith & Thompson, 2017). Metal decking, often used in industrial applications, provides superior strength and fire resistance (Chung, 2005). The axial decking machine's ability to handle these varied materials with precision is essential in modern construction environments where different materials may be required for different applications.

3. Precision and Efficiency in Decking Installation: Automation is essential in improving the precision and efficiency of construction operations. A major benefit of machines like the axial decking machine is their ability to perform repetitive tasks with minimal deviation, leading to improved outcomes in terms of both speed and quality (Shewchuk & Guha, 2014). By automating the decking installation process, contractors can reduce labour costs, minimize errors, and speed up project timelines. Studies on automation in repetitive construction tasks, such as those by Al-Hussein et al. (2005), show that automated systems significantly reduce the time needed for installations while maintaining high levels of accuracy. Moreover, these machines can minimize the need for skilled labour, which is a growing concern in the construction industry due to labour shortages in many regions.

1. Safety in Automated Construction Machines: Safety is a critical consideration in the use of automated construction machinery. Modern axial decking machines are designed with various safety features, including emergency stop systems, motion sensors, and safety guards (Kumar 2021). These features help ensure that operators remain safe during the machine's operation and comply with industry regulations. According to Liu and Borelli (2018), the integration of advanced safety systems in construction machinery reduces the risk of accidents and enhances operator confidence in using the equipment. The importance of safety in automation is emphasized in various standards and guidelines, such as those from the Occupational Safety and Health Administration (OSHA), which mandates specific safety protocols for construction equipment (OSHA, 2019).

8. Cost-Benefit Analysis of Automated Decking Installation:

The cost implications of adopting automated decking machines have been a subject of considerable study. While the initial investment in automation technology, such as axial decking machines, can be significant, long-term cost savings are realized through reduced labour, faster project completion, and improved quality control. Studies by Bock and Limner (2016) show that automation in construction can reduce labour costs by up to 30% and increase productivity by 25-40%, especially in repetitive tasks such as decking installation. Moreover, the reduction in material waste, a key feature of automated machines, leads to further cost savings. According to a study by Tam et al. (2007), automated systems in construction projects can reduce material waste by as much as 15%, primarily due to the precision with which the machines operate. This costbenefit analysis makes the axial decking machine an attractive option for contractors seeking to balance up-front costs with long-term economic gains. Additionally, the improved speed and quality of installation often lead to better client satisfaction and the potential for increased business opportunities in competitive markets.



Fig.01 Axial Decking Machine Mechanical Model

Methodology

The first step in this project involves conducting comprehensive research on existing decking machines and axial motion technologies. The objective is to identify the strengths and limitations of current solutions and incorporate these insights into the design of the axial decking machine.

Literature Review: An in-depth review of previous studies, research papers, and patents related to decking installation technologies will be conducted. This will inform the design and operational principles of the machine.

Design Specifications: Based on the literature review, the specifications of the axial decking machine will be developed. This includes defining the range of motion, material compatibility (wood, composite, metal), cutting mechanisms, control systems, and safety features.

Mechanical Design and CAD Modelling: Once the design specifications are finalized, Computer-Aided Design (CAD) software such as SolidWorks or AutoCAD will be used to create detailed mechanical drawings of the axial decking machine.

3D Modelling: A 3D model of the machine will be created to visualize the mechanical components, frame structure, axial movement system, and material handling mechanisms

Component Selection: The necessary components such as motors, linear actuators, ball screws, pneumatic or hydraulic systems, cutting tools, and safety sensors will be selected based on the machine's design requirements.

Finite Element Analysis (FEA): FEA simulations will be carried out to test the strength and stability of the machine's frame and moving components. This will ensure the machine can handle different decking materials without structural deformation.

Control System Development: The axial decking machine will require a robust control system to automate its operations. This involves the integration of both hardware and software to enable precise control of the machine's functions.

Programmable Logic Controller (PLC) Programming: A PLC will be programmed to control the machine's axial movement, cutting tool operation, and material handling. The control logic will be designed to allow for real-time adjustments in response to varying material properties and environmental conditions.

Human-Machine Interface (HMI): An HMI will be developed to allow operators to interact with the machine. The HMI will display key parameters such as cutting speed, material feed rate, and emergency stop options, making the machine user-friendly and safe.

Sensors and Feedback Systems: Sensors such as limit switches, proximity sensors, and load cells will be integrated to provide feedback to the control system. This ensures precise positioning and consistent performance, allowing the machine to adjust automatically for material.

Prototyping and Fabrication: Following the design and control system development, a prototype of the axial decking machine will be fabricated to test its functionality.

Fabrication: The machine's components will be sourced and assembled according to the CAD design. Special attention will be paid to the axial movement mechanism to ensure smooth and accurate motion.

Assembly: The mechanical components (frame, actuators and cutting tools) will be assembled, and the control systems (PLCs, sensors) will be wired and integrated with the machine.

Testing of Subsystems: Individual subsystems, such as the material feeding system, cutting tool, and axial movement controls, will be tested to ensure each operates as intended.

Testing and Validation: Once the prototype is assembled, rigorous testing will be performed to evaluate the machine's performance, accuracy, and efficiency.

Functional Testing: The machine will be tested under different operating conditions, including varying speeds, material types (wood, composite, metal), and board dimensions. The tests will measure the machine's ability to align and cut decking boards with high precision.

Efficiency Testing: The machine's cycle time will be measured to determine its efficiency in decking installation compared to manual labour or existing decking machines.

Material Waste Analysis: A waste analysis will be performed to quantify the amount of material saved by using the axial decking machine. This will include an assessment of cutting accuracy, misalignment, and defective cuts.

Safety Testing: Safety features such as emergency stop buttons, safety guards, and sensor systems will be evaluated for their effectiveness in preventing accidents or equipment damage.

Data Collection and Analysis: The results from the testing phase will be analysed to assess the machine's performance.

Quantitative Data: Data on material waste, cycle times, energy consumption, and machine efficiency will be collected and statistically analysed to determine the machine's effectiveness compared to traditional methods.

Qualitative Data: Observations of machine operation and feedback from test operators will be recorded to identify any usability or safety issues.

Comparison to Benchmarks: The results will be compared against industry benchmarks for decking installation machines, evaluating the axial decking machine's competitive advantage in terms of precision, speed, and cost-effectiveness.

The construction of the axial decking machine involves several critical components, each designed to contribute to the overall function and precision of the machine. The following sections describe the key components and their roles.



Fig.02 Axial Decking Machine Mechanical Model

Frame: The machine's frame is a sturdy structure made of high-strength steel or aluminium. It provides a stable foundation to support the machine's operations, ensuring minimal vibrations during cutting and

alignment of decking boards. The frame includes mounting points for other components such as the cutting tools, axial movement mechanisms, and material feeding system.

Axial Movement Mechanism: This is the core of the machine and enables precise linear movement of the cutting head or material feeding system. Typically, this mechanism includes: **Ball Screws or Linear Actuators:** These are responsible for converting rotary motion into precise linear motion along the axis. Ball screws are ideal for high precision, while linear actuators can be driven by electric or pneumatic systems, depending on the design.

Guiding Rails: The guiding rails ensure that the movement is smooth and controlled along the axial direction, minimizing friction and deviation during operation.

Cutting Mechanism: The cutting head or tool is designed to cut or shape decking materials such as wood, composite, or metal. Depending on the material being handled, the machine might include.

Circular Saw: Common for wood and composite materials.

Plasma or Laser Cutter: Typically used for metal decking. The cutting mechanism is mounted on the axial movement system, allowing it to move precisely over the decking boards. **Material Handling System:** This system feeds decking boards into the machine for cutting and alignment.

Conveyor Belts or Rollers: Used to move the decking materials into the machine for processing.

Clamping Mechanisms: These ensure that the decking boards are securely held in place during cutting to avoid misalignment.

Control System: The machine is controlled by a **Programmable Logic Controller (PLC)**, which manages the movement of the axial mechanism, cutting operations, and material feeding.

The control system also integrates safety features such as:

Emergency Stop: Shuts down the machine in case of a safety hazard.

Proximity Sensors and Limit Switches: Used to ensure that the

cutting head or material movement stops at the required points, preventing over-travel or collision.

Human-Machine Interface (HMI): The HMI provides the operator with an easy-to-use control panel, allowing for input of parameters such as cutting speed, material type, and cutting length. The interface also provides real-time feedback on machine status and error notifications.

Loading and Positioning of Decking Material: Decking boards are loaded onto the conveyor belt or rollers of the material handling system. The clamping mechanisms secure the decking boards to prevent movement during cutting. The machine's sensors ensure that the material is correctly positioned before initiating the cutting process.

Axial Movement for Alignment and Cutting: The machine's control system calculates the required movement and cutting parameters based on the material type, size, and project specifications entered by the operator via the HMI. The axial movement mechanism, driven by the ball screws or linear actuators, moves the cutting head or material along the designated axis. This allows the machine to precisely align the cutting tool to the correct location on the decking board. Once aligned, the cutting tool (such as a circular saw or plasma cutter) is activated, making a clean cut along the material.

Material Feed and Repeat Operation: After each cut, the machine automatically advances the decking board for the next operation. This is managed by the material handling system, which moves the board into position for the next cut or alignment step. The machine continues this process in a loop, repeating the cycle until the entire decking material has been processed according to the specified dimensions.

COMPONENTS :

4.1 PLC Allen-Bradley:

Allen-Bradley is a brand of industrial automation equipment and control systems, owned by Rockwell Automation. It is well-known for its Programmable Logic Controllers (PLCs), which are widely used in various industries for automation and control applications. Here's an overview of Allen-Bradley PLCs.



Fig.03 Allen Bradley PLC (MICROLOGIX 1400)

Key Features of Allen-Bradley PLCs:

4.1.1. Modular Design: Many Allen-Bradley PLCs, such as the Control Logix and Compact Logix series, feature a modular design that allows users to customize their systems with various input/output (I/O) modules, communication modules, and specialty modules to meet specific application needs.

4.1.2 Scalability: Allen-Bradley PLCs are designed to be scalable, making them suitable for small applications as well as large, complex systems. Users can easily expand their systems by adding more modules or controllers as needed.

4.1.3 Programming Software: Allen-Bradley PLCs are programmed using Rockwell Automation's RS Logix 5000 or Studio 5000 software, which provides a user-friendly interface for developing, testing, and

troubleshooting control programs. The software supports various programming languages, including Ladder Logic, Function Block Diagram, and Structured Text.

4.1.4 Integrated Communication: Allen-Bradley PLCs support various communication protocols, including Ethernet/IP, Device Net, and ControlNet, allowing for seamless integration with other devices and systems in an industrial environment.

4.1.5 User Support and Resource: Rockwell Automation provides extensive documentation, training resources, and technical support for Allen-Bradley products, helping users effectively implement and maintain their automation systems.

4.2 Hydraulic Double-Acting Cylinder: A hydraulic double-acting cylinder is a type of actuator that converts hydraulic energy into mechanical energy to produce linear motion. It is widely used in various industrial applications, including construction machinery, manufacturing equipment, and automotive systems. Here's a detailed overview of hydraulic double-acting cylinders:

4.2.1 Double-Acting Mechanism: Unlike single-acting cylinders, which can only exert force in one direction, double-acting cylinders can apply force in both the extending and retracting strokes. This is achieved by using hydraulic fluid to push the piston in both directions, allowing for more versatile and efficient operation.

4.2.2 Piston and Rod Design: The cylinder consists of a cylindrical barrel, a piston, and a piston rod. The piston divides the cylinder into two chambers: the rod side (A) and the cap side (B). Hydraulic fluid is directed into one chamber to extend the piston and into the other chamber to retract it.

4.2.3 Hydraulic Fluid Control: The movement of the piston is controlled by hydraulic valves that regulate the flow of hydraulic fluid into and out of the cylinder chambers. This allows for precise control of the speed and force of the cylinder's movement.

4.2.4 Sealing Mechanisms: Double-acting cylinders are equipped with seals to prevent hydraulic fluid leakage and to maintain pressure within the cylinder. Common sealing types include O-rings, rod seals, and wiper seals.

4.2.5 Mounting Option: Hydraulic double-acting cylinders come with various mounting configurations, such as clevis, trunnion, and flange mounts, allowing for flexible installation in different applications installed in an electrical panel or control cabinet using DIN rail mounting or other suitable methods.

4.3 Solenoid valves: Solenoid valves are electromechanical devices used to control the flow of fluids (liquids or gases) in various applications. They operate by using an electromagnetic solenoid to open or close the valve, allowing for precise control of fluid flow. Here's a detailed overview of solenoid valves, including their types, working principles, applications, and advantages



Fig.04 Yuken Solenoid Valve (MPW-01-02-40H01)

Electromechanical Operation: Solenoid valves consist of a coil (solenoid) and a movable plunger or armature. When electrical current passes through the coil, it generates a magnetic field that moves the plunger, opening or closing the valve.

Types of Solenoid Valves: Direct-Acting Solenoid Valves: These valves operate directly from the solenoid's magnetic force. They are typically used for smaller flow rates and lower pressure applications. Pilot-Operated Solenoid Valves: These valves use the pressure of the fluid to assist in opening and closing the valve. They are suitable for larger flow rates and higher pressure applications. Normally Closed (NC) and Normally Open (NO): Solenoid valves can be designed to be normally closed (the valve is closed when no power is applied) or normally open (the valve is open when no power is applied).

Sizes and Configurations: Solenoid valves come in various sizes and configurations, including 2-way, 3-way, and 4-way designs, allowing for different flow paths and control options.

4.4 Contactor:

A contactor is an electromechanical switch used to control the flow of electrical power in various applications, particularly in industrial and commercial settings. It is designed to switch electrical circuits on and off, allowing for the control of motors, lighting, heating, and other electrical loads. Here's a detailed overview of contactors, including their features, working principles, applications, and advantages.



Fig.05 Siemens Contactor (3TF30 10-0B)

Electromechanical Operation: Electromechanical Operation: A contactor consists of an electromagnetic coil and one or more sets of contacts. When electrical current flows through the coil, it generates a magnetic field that moves the contacts to either open or close the circuit.

Types of Contacts: Normally Open (NO): Contacts that are open when the coil is de-energized and close when the coil is energized. Normally Closed (NC): Contacts that are closed when the coil is de-energized and open when the coil is energized.

Coil Voltage: Contactors are available in various coil voltages (AC or DC), allowing them to be used in different electrical system.

Current Rating: Contactors come in various sizes and current ratings, enabling them to handle different load

ELCB (Earth Leakage Circuit Breaker): ELCB (Earth Leakage Circuit Breaker) is a safety device used in electrical installations to prevent electric shock and electrical fires caused by earth faults. It detects leakage currents that may occur when there is a fault in the electrical system, such as insulation failure or accidental contact with live parts. Here's a detailed overview of ELCBs, including their features, working principles, types, applications, and advantages

Fault Detection: ELCBs continuously monitor the current flowing through the live and neutral wires. If there is a difference in current (indicating leakage to the ground), the ELCB will trip and disconnect the circuit.

Protection against Electric Shock: By detecting earth faults, ELCBs help protect individuals from electric shock, especially in wet or damp environments where the risk is higher.

Fire Prevention: ELCBs can prevent electrical fires caused by leakage currents that may ignite flammable materials.

Manual Reset: After tripping, ELCBs typically require a manual reset to restore power, ensuring that the fault is addressed before re-energizing the circuit. Capacities, from small appliances to large industrial motors.

APPLICATIONS :

Applications of Axial Decking Machines: Axial decking machines are widely used in the construction industry, primarily for producing metal decking systems that serve as structural components in various building and infrastructure projects. Their ability to produce highstrength, lightweight metal decking profiles makes them crucial in modern construction. Below are the key applications of axial decking machine.

Roofing System: One of the most common applications of axial decking machines is the production of metal roofing decks. These decks are used as a base layer for roofing in commercial, industrial, and residential buildings. The profiles created by these machines are designed to support roofing materials like waterproofing membranes, insulation, or even photovoltaic systems.

Structural Roofing Decks: Metal decking produced by axial machines provides strength and stability to roofing structures, allowing them to support heavy loads, including HVAC units or solar panels.

Weather Resistance: Metal roofs produced by axial decking machines are highly resistant to environmental conditions such as rain, snow, and extreme temperatures due to the durability of the materials used, like galvanized steel or aluminium.

Flooring Systems (Composite Floor Decking): Axial decking machines are used to produce composite floor decking, where metal decking serves as a formwork for concrete slabs.

The metal profile not only acts as a mould for the concrete but also enhances the load-bearing capacity of the floor once the concrete hardens.

Concrete Reinforcement: The ribs and corrugations in the metal decking create a strong bond with the concrete, improving its structural integrity. This is particularly useful in multi-story buildings, warehouses, and parking structures.

Time and Cost Efficiency: Metal decking speeds up the construction process as it eliminates the need for temporary wooden formwork and reduces the amount of concrete required.

Bridges and Infrastructure: Axial decking machines are also applied in the production of metal decking for bridges and other infrastructural projects. Metal decks in these applications serve as a lightweight yet durable surface that can support vehicular or pedestrian traffic.

Bridge Decking: Metal decking produced by axial machines is often used as permanent framework for concrete bridge decks, providing both strength and stability to the structure. Long Span Capabilities: Axial decking is used in long-span bridge designs, where its light weight helps reduce the overall load on the bridge structure while maintaining strength.

Commercial and Industrial Buildings: In large-scale commercial and industrial construction, axial decking machines are used to create durable metal floor and roof decking systems. These decks are commonly seen in buildings such as warehouses, shopping malls, office complexes, and manufacturing plants.

Heavy Load-Bearing: The metal decking systems provide high strength-to-weight ratios, allowing them to bear heavy loads, including machinery, equipment, or multi-level structures.

Fire Resistance: Steel decking profiles produced by axial decking machines offer improved fire resistance when used with proper coatings and treatments, making them ideal for industrial settings.

Residential Construction: Axial decking machines are increasingly being used in residential construction, especially in modern housing developments where metal decking systems are employed for both roofs and floors.

Sustainable Housing: Metal decks can be integrated with energy-efficient building designs, including green roofs, insulated roof systems, and underfloor heating setups.

Customizable Designs: With the help of axial decking machines, contractors can create custom profiles and designs suited to residential architectural needs, including curved or lightweight decking systems for specific building styles.

Stadiums and Large Venues: Axial decking machines are often used to produce metal decking systems for large structures such as stadiums, convention centres, and arenas. In these cases, the metal decking provides structural support for roofs, walkways, and seating areas.

Large Span Roofing: Metal decking systems created by axial machines can cover large spans without the need for numerous internal supports, making them ideal for venues with wide open spaces.

Acoustic and Insulation Properties: Metal decks can be combined with insulation and acoustic materials, helping to control noise levels and maintain thermal comfort in large spaces.

Temporary Structures: Metal decking produced by axial decking machines is also used for temporary structures, such as those required during construction or events.

FUTURE SCOPE :

Future Scope of Axial Decking Machines:

As construction demands evolve and technology continues to advance, axial decking machines have the potential for significant development in terms of efficiency, sustainability, and application diversity. The future scope of axial decking machines involves improvements in automation, materials, design flexibility, and integration with emerging technologies. Below are the key areas where axial decking machines are likely to advance.

Increased Automation and AI Integration:

One of the most promising future developments for axial decking machines is the integration of advanced automation and artificial intelligence (AI) systems. Automation and AI could revolutionize how these machines operate, manage production, and ensure quality control. **Smart Manufacturing:** AI-powered systems can monitor machine performance, detect potential issues, and automatically adjust parameters to optimize production. This reduces downtime, increases productivity, and ensures consistent quality.

Predictive Maintenance: AI and machine learning algorithms could be employed to predict when maintenance is required based on machine usage data, thus minimizing unexpected breakdowns and improving overall equipment efficiency.

Fully Automated Production Lines: The future of axial decking machines could see fully automated production lines where human intervention is minimal. This would enable continuous operation, higher throughput, and reduced labour costs.

Enhanced Sustainability and Eco-Friendly Operations:

The construction industry is under increasing pressure to reduce its carbon footprint, and axial decking machines have the potential to contribute to this effort by adopting more sustainable practices.

Energy Efficiency: Future axial decking machines are expected to incorporate more energy efficient motors and hydraulic systems. Using renewable energy sources or optimizing power usage through advanced control systems can reduce the environmental impact.

Recyclable Materials: Machines capable of processing a wider range of recyclable and environmentally friendly materials will be in demand. This includes producing decking from recycled metals or hybrid materials that are lighter and more sustainable.

Waste Reduction: Improved precision and material handling technology can minimize waste generated during the decking production process, ensuring more efficient use of raw materials.

Customizable and Modular Decking Profiles:

Future axial decking machines may offer greater flexibility in producing highly customized and modular decking profiles. These machines could handle intricate designs, special requests, and adaptive systems more efficiently.

Dynamic Profile Design: Machines may be equipped with software that allows operators to easily switch between different deck profiles or create entirely new custom designs to meet specific architectural or structural needs.

Rapid Customization: The ability to quickly adjust machine settings to produce customized profiles for niche applications, such as curved or non-standard shapes, will be a valuable feature for the construction industry.

Advanced Materials and Multi-Material Decking:

The use of new and advanced materials in construction is expanding. Axial decking machines could be adapted to process not only traditional metals like galvanized steel and aluminium but also advanced composite materials, which are lightweight yet strong.

Hybrid Decking Systems: In the future, axial decking machines could

produce hybrid decks made from combinations of metals and composites, optimizing strength, weight, and durability for different applications such as high-rise buildings or long-span bridges.

High-Strength, Lightweight Materials: Processing of new alloys and high-strength steel or aluminium could become more common, enabling the production of even lighter yet stronger decking systems. This would benefit projects where weight reduction is critical, such as in aerospace or offshore applications.

Integration with Digital Construction Technologies (BIM and IoT):

Axial decking machines may increasingly integrate with digital construction technologies, such as Building Information Modelling (BIM) and the Internet of Things (IoT), to streamline the design-to-production process.

BIM Compatibility: In the future, axial decking machines could be directly integrated into BIM platforms, enabling architects and engineers to design decking profiles that are optimized for production. This seamless integration would reduce errors, improve communication, and speed up the construction process.

IoT-Enabled Machines: IoT sensors and networks could allow real-time monitoring and remote control of axial decking machines. This would enable operators to track performance metrics, troubleshoot issues, and even control machines from a distance, improving overall efficiency and reducing the need for on-site personnel.

High-Speed Production and Productivity Improvements:

The demand for faster construction processes is driving innovation in manufacturing equipment. Future axial decking machines are expected to increase production speeds and improve overall productivity without sacrificing quality.

Higher Output Capacity: Advances in machine design, roller technology, and material handling systems will allow for higher production speeds, making it easier to meet large-scale project deadlines.

Precision and Quality at High Speed: Future developments will likely focus on achieving consistent precision and high-quality profiles, even when operating at maximum speeds, ensuring that increased productivity does not compromise product quality.

Application in Emerging Construction Methods (e.g., Modular and Prefabrication):

The trend toward modular construction and prefabrication is creating new opportunities for axial decking machines. These machines could play a key role in producing decking systems that are pre-assembled or customized off-site.

Prefabricated Systems: Axial decking machines could be optimized for producing components that are part of larger prefabricated building modules, streamlining the construction process and reducing on-site assembly time.

Modular Decking Systems: The machines could be designed to produce modular decking panels that can be easily transported and assembled on-site, especially for high-rise buildings and large infrastructure projects.

Enhanced Safety and Operator Interface:

Safety and ease of use will continue to be critical aspects of future axial decking machine development. Machines will become more operator-friendly, with improved safety features and interfaces.

Ergonomic Design: Future machines may feature more intuitive and ergonomic controls, making them easier to operate for workers with less technical expertise.

Safety Enhancements: Enhanced safety features, such as real-time hazard detection systems, automatic shutdown in case of malfunctions, and improved guarding mechanisms.

Global Expansion and Adoption:

As infrastructure development grows globally, especially in developing regions, axial decking machines will likely see increased adoption.

Adapting to Local Markets: Manufacturers will likely develop machines tailored to the specific needs of local markets, such as machines optimized for processing locally available materials or those suited to different climate conditions.

Expansion in Emerging Markets: The construction boom in regions like Asia, Africa, and Latin America will drive the demand for cost-effective and efficient axial decking machines, which can accelerate infrastructure development and address housing shortages.

Sustainability in Construction (Net-Zero and Green Buildings):

The construction industry is moving towards sustainability with goals like net-zero energy consumption and green building certifications. Axial decking machines can contribute to these goals by producing decking systems that improve the energy efficiency of buildings. **Energy-Efficient Decking Systems:** Future machines could produce decking profiles designed to support energy-efficient building systems, such as insulated roof decks, solar-integrated decks, or decking that improves thermal performance.

Recyclable and Sustainable Materials: The ability to process materials that are recyclable or derived from sustainable sources will make axial decking machines crucial in green building projects.

The future of axial decking machines is marked by technological advancements, increased efficiency, and greater adaptability to evolving construction methods and sustainability demands. These machines will play a critical role in the modernization of construction, offering solutions for faster, safer, and more eco-friendly building practices.

CONCLUSION :

Axial decking machines have become an essential technology in the modern construction industry, offering efficient and reliable solutions for producing metal decking systems used in a wide variety of applications. Their ability to create strong, durable, and versatile decking profiles makes them indispensable for structural components in roofing, flooring, bridges, and many other infrastructure projects.

The key advantages of axial decking machines include:

High Production Efficiency: These machines allow for rapid production of decking profiles, significantly speeding up construction timelines and reducing labour costs.

Material Versatility: Capable of processing various metals, such as galvanized steel and aluminium, axial decking machines provide flexibility for different types of projects, from residential buildings to large-scale commercial structures.

Precision and Quality: With advanced roll-forming technology, these machines ensure the production of highly precise, uniform decking profiles that meet the stringent quality standards required for structural integrity and safety.

Customization Capabilities: The ability to produce a wide range of decking profiles tailored to specific project needs enhances their adaptability in different construction scenarios.

Looking ahead, axial decking machines are poised for further growth and development. Integration of automation, AI, and digital construction technologies will increase their efficiency and expand their application potential. Additionally, the adoption of eco-friendly materials and sustainable manufacturing practices will align them with the broader trend toward green construction and energy-efficient buildings.

In conclusion, axial decking machines represent a cornerstone of modern construction, providing both efficiency and flexibility.

REFERENCES :

Academic and Technical Paper:

1. Amin, M., & Mohamed, A. (2019). Performance Analysis of Cold-Formed Steel Decking in Composite Construction Systems. *Journal of Structural Engineering*.
2. Chen, C., & Li, X (2021). Design and Application of Metal Decking Profiles for MultiStory Building Construction *Technology Journal*.
3. Tang, Y., & Zhang, L (2018). The Application of Cold-Formed Steel Decking in HighRise Buildings *International Journal of Civil Engineering and Structural Design*.
4. Silva, P., & Martins, A (2020). Cold-Formed Steel Design for Roofing and Decking Applications: Advances in Roll-Forming Technology. *Journal of Advanced Building Materials*.

Industry Reports and White Papers:

1. Steel Deck Institute. (2020). *Steel Decking Manual: Guidelines for the Use and Design of Metal Decks*. Steel Deck Institute.
2. National Roofing Contractors Association. (2019). *Metal Decking and Roofing Systems: Technical Guidelines for Design and Installation*. NRCA Roofing Handbook.
3. ArcelorMittal Construction. (2021). *Axial Decking Machines and Metal Decking Solutions for Industrial and Commercial Buildings*. ArcelorMittal Technical Guide.
4. Roll form Equipment Pvt Ltd. (2022). *Advancements in Axial Decking Machines and Roll-Forming Technology*.

Manufacturer and Technical Manuals:

1. Bradbury Group. (2020) *Operation and Maintenance of Axial Decking Machines: Technical Manual*. Bradbury Group Equipment Guide.
2. ASC Machine Tools Inc. (2021). *Axial Decking Systems: Technical Specifications and Applications*.

3.DEVELOPMENT OF PLC BASED PNEUMATICS TRAINER KIT

Name of Students: Bhavna Dnyaneshwar More
Harsh Manoj Chaudhari
Akash Govind Pole

Year: B.E. :2024-25

Title: Development of plc based pneumatics trainer kit

ABSTRACT :

This Project presents a pneumatic system designed to automate document processing and use a PLC to control the ball valve. This system has a variety of pneumatic components, such as double-acting cylinders, solenoid valves, vacuum cups and ball valves. The main function of the system is to use a vacuum cup to lift and move the leaves. The movement of the sheet is controlled by a solenoid valve that controls the flow of air into the vacuum cup. A PLC is used to provide the necessary solenoid valve control signals, enabling precise and automatic sheet control. In addition, the system includes a ball valve driven by pneumatics.

This actuator is connected to an AND,OR gate allowing flexible control of the ball valve position depending on input conditions. The PLC is responsible for sending the correct signals to the AND,OR table indicating the position of the ball valve. The combination of these features results in a versatile and efficient pneumatic system capable of performing a variety of paper and valve control functions. The PLC plays a vital role in ensuring precise system operation and reliable, allowing it to adapt to different needs and applications used

INTRODUCTION :

1.1 Introduction of the Project Work

This project focuses on the design and implementation of a pneumatic circuit controlled by a Programmable Logic Controller (PLC). The system automates the operation of a ball valve and sheet handling process using various

pneumatic components, such as rotary actuators, double-acting cylinders, vacuum generators, and solenoid valves. The ball valve is controlled via a double pilot 5/2 valve with AND,OR gate logic, allowing for conditional operation based on system inputs. Additionally, the vacuum cup system, essential for handling and transferring materials, is controlled by a solenoid valve to manage suction and release operations with high precision.

The use of a PLC in this system ensures seamless coordination between components and enables complex logic-based control sequences. Through automation, the system optimizes operational efficiency, ensuring smooth and reliable performance for fluid control and material handling tasks. This project serves as a demonstration of how pneumatic systems can be effectively integrated with PLCs to automate industrial processes and improve overall system performance. One of the key advantages of pneumatic systems is their ability to generate powerful, rapid movements, making them ideal for applications involving fluid control and material handling.

1.2 Problem Statement

This report presents an engaging demonstration model of pneumatic ball valve control featuring AND and OR operations, integrated with a pick and place system using two cylinders. It highlights essential concepts in automation and pneumatic technology, blending logic with practical applications. This innovative approach aims to inspire learners and equip them for real-world industrial challenges.

1.3 Objectives

- i. **To demonstrate the integration of pneumatic components with PLC-based automation:**
The trainer kit will showcase how pneumatic elements like cylinders, vacuum cups, solenoid valves, and rotary actuators can be effectively controlled using a Programmable Logic Controller (PLC).
- ii. **To illustrate the operation of a ball valve using AND/OR gate logic:** This project will demonstrate how logical operations (AND/OR) can be used to control the flow of fluids through a ball valve, providing learners.
- iii.
- iv. **To demonstrate the use of a vacuum generator for efficient material handling:**
The trainer kit will allow users to explore how a vacuum generator creates suction to securely lift and move sheets or other materials. This will help learners understand the practical application of vacuum technology in industrial automation systems.
- v. **To provide hands-on experience with the control of a double-acting cylinder in material movement:**
The trainer kit will showcase how a double-acting cylinder, in coordination with the vacuum generator, is used to perform precise, controlled movements for material handling. This will give learners insight into how pneumatic cylinders contribute to the automation of tasks in industrial settings.
- vi. **To enhance understanding of pneumatic circuit design and troubleshooting:**
Through the trainer kit, learners will gain insights into pneumatic circuit design, the role of components such as manifolds, FRL units, and the use of solenoid valves, providing a hands-on platform for diagnosing and troubleshooting system issues.

vii. **To encourage safety and best practices in pneumatic and PLC-controlled systems:**

The trainer kit will emphasize the importance of safety and best practices when working with pneumatic systems and PLC automation, promoting the proper handling of compressed air systems and electrical components.

1.4 Scope of the Project Work

- **Enhanced Automation:** The integration of PLCs with pneumatic systems allows for precise control and automation of processes, reducing the need for manual intervention. This leads to increased efficiency and productivity in industrial operations.
- **Improved System Reliability:** By utilizing PLCs to manage pneumatic components, the system can ensure consistent and reliable operation. This reduces the likelihood of errors and enhances overall system performance, resulting in fewer downtimes and maintenance requirements.
- **Flexibility in Operations:** The programmable nature of PLCs enables easy reconfiguration and modification of control logic. This flexibility allows the system to adapt to changing operational needs and requirements without significant hardware changes.
- **Optimized Resource Utilization:** Automating the ball valve operation and sheet handling process can lead to better utilization of pneumatic resources.

- **Skill Development:** The project provides students with hands-on experience in designing and implementing pneumatic systems and programming PLCs. This practical knowledge is valuable in preparing them for careers in automation and industrial engineering, making them more competitive in the job market.

HARDWARE AND SOFTWARE REQUIREMENTS :

- **Compressor**

A compressor is a mechanical device that increases the pressure of air or gas by reducing its volume. In pneumatic systems, compressors are essential for generating the compressed air required to power various components like actuators, valves, and tools. The basic operation of a compressor involves drawing in air, compressing it using mechanical means, and then discharging it at a higher pressure.



In this project, a reciprocating air compressor is utilized to provide the compressed air necessary for the operation of the pneumatic circuit. Indo Air offers a range of high-quality compressors, including models that deliver significant power and efficiency for various applications. designed to meet the demands of industrial and commercial pneumatic systems.

- **FRL**

FRL stands for **Filter, Regulator, and Lubricator**, and it is a critical component in pneumatic systems. The FRL unit serves to ensure that the compressed air used in pneumatic applications is clean, properly regulated, and adequately lubricated. Each component of the FRL unit plays a specific role:

Filter: The filter removes contaminants, such as dust, dirt, and moisture, from the compressed air. This is crucial because impurities can cause wear and tear on pneumatic components, leading to decreased efficiency and increased maintenance costs.

Regulator: The regulator controls and maintains the air pressure within the pneumatic system. It allows for the adjustment of air pressure to meet the specific requirements of different pneumatic components and tools, ensuring optimal performance and preventing damage due to overpressure.

Lubricator: The lubricator adds a fine mist of oil to the compressed air to ensure proper lubrication of pneumatic components. This is particularly important for moving parts, as it reduces friction and wear, extending the life of the equipment.



■ **Single and double acting cylinder**

A single-acting cylinder operates by using compressed air to extend the piston in one direction, while a spring or external force retracts it back to its original position. This design typically features a single air port for air intake, making it simpler and more cost-effective than its counterpart, the double-acting cylinder. The retraction is achieved through the force of the spring or gravity, allowing for straightforward applications where only one direction of movement is required. Single-acting cylinders are commonly used in applications such as clamping mechanisms, where the weight of the object or a spring can aid in returning the cylinder to its starting position.



A double-acting cylinder is designed to use compressed air for both extending and retracting the piston, allowing for greater control and versatility in motion. It features two air ports—one for applying pressure to extend the piston and another for retracting it. This design enables the cylinder to generate force in both directions, making it suitable for applications that require precise control over movement and speed. Double-acting cylinders are widely used in automation, robotics, and material handling systems.

- **Double solenoid valve 5/2**

Its directional control valve used in pneumatic systems, featuring five ports and two positions. This valve utilizes two solenoid coils to control the movement of the valve spool, allowing for precise control of airflow to double-acting cylinders. When one solenoid is energized, the spool shifts to direct compressed air to extend the cylinder; when the other solenoid is activated, the spool shifts again to allow for retraction.



This efficient design enables quick and reliable control of linear motion in various applications, such as automation, robotics, and material handling, making it a vital component in many industrial processes.

- **spool operated single solenoid 3/2 valve**

directional control valve used in pneumatic systems, characterized by three ports and two positions. This valve operates with a single solenoid that shifts a spool between two positions to control the airflow. When the solenoid is energized, the spool directs compressed air from the supply port to one outlet while venting the other outlet to the atmosphere. This design is commonly employed to control single-acting cylinders or other devices that require

movement in one direction, relying on a spring or external force for retraction.



- **Flow Control Valve**

A flow control valve is a critical component in pneumatic systems that regulates the flow rate of fluids, including air and liquids. By adjusting the size of the flow passage, these valves enable precise control over the speed of actuators, such as cylinders and motors, allowing for smooth and consistent operation. Flow control valves can be either manual or automatic, with manual valves typically using a handwheel or knob to set the desired flow rate, while automatic valves utilize pressure or electronic signals for regulation.



- **Quick exhaust valve**

A **quick exhaust valve** is a specialized pneumatic device designed to enhance the speed of actuator response by allowing compressed air to exhaust rapidly from a cylinder when it is not in use. Installed directly on the cylinder, this valve features a unique design that enables it to quickly release the air trapped in the cylinder, significantly reducing the time it takes for the actuator to retract.



By providing a direct path for the exhaust air while maintaining the supply of compressed air for extension, quick exhaust valves improve overall cycle times in automated systems.

- **Push button valve**

it is a type of pneumatic control valve that is manually operated by pressing a button, allowing users to easily control the flow of compressed air to various pneumatic devices. When the button is pressed, the valve opens, directing air to the connected components, such as cylinders or tools, to activate them. This simple design makes push button valves ideal for applications requiring quick and straightforward operation, such as in machinery and assembly lines. They can be configured for various functions, including momentary where the valve returns to its default state when released or

maintained where the valve stays in the activated position until pressed again.



- **AND & OR Gate**

The basic operation of AND & OR gates in pneumatic systems involves controlling outputs based on input conditions. An AND gate requires all its inputs to be true for the output to be activated, meaning that a pneumatic actuator or valve will only operate when all specified conditions are met, ensuring safety and proper sequencing.

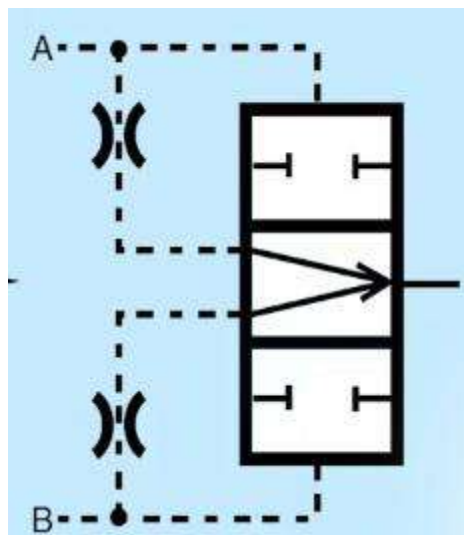

In contrast, an OR gate activates the output if at least one of its inputs is true, allowing for greater flexibility; this means that a pneumatic device can be triggered by any one of

multiple conditions being satisfied, enabling redundancy and responsiveness in various applications.

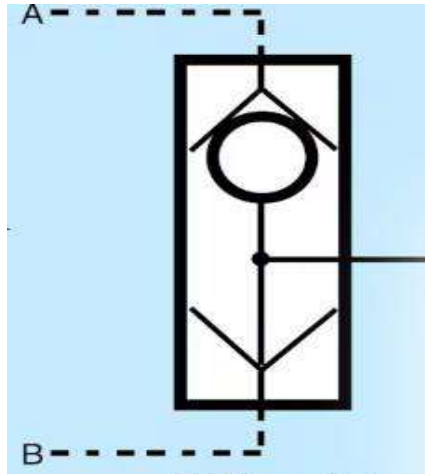

- **BALL Valve**

A ball valve is a type of quarter-turn valve used to control the flow of liquids or gases in a piping system, characterized by a spherical disc (the ball) that rotates to open or close the flow path. When the valve is fully opened, the ball's hole aligns with the pipeline, allowing for unrestricted flow; when closed, the ball turns 90 degrees to block the flow entirely. Ball valves are known for their durability, reliability, and low resistance to flow, making them suitable for a wide range of applications, including water supply, gas distribution, and industrial processes.



- **Vacuum Cup and Vacuum Generator**

A vacuum cup is a device used to create a vacuum seal with a surface, allowing for the reliable gripping and handling of objects in various applications, such as material transfer and assembly processes. Typically made of flexible materials, vacuum cups conform to the shape of the object being lifted, providing a secure grip.



To generate the necessary vacuum, a vacuum generator is used, which can be pneumatic or electric. Pneumatic vacuum

generators often use compressed air to create a vacuum by expelling air through a venturi or by using a mechanical pump, resulting in a drop in pressure that creates suction. Together, vacuum cups and generators are widely utilized in automation and industrial applications, enhancing efficiency and precision in handling delicate or heavy items without damaging them.



- **Working Of Ball Valve**

The operation of the ball valve is controlled through a combination of **AND** and **OR** gates to ensure precise and conditional control based on various input signals. The **AND gate** is used to ensure that the ball valve opens only when multiple conditions are met simultaneously, such as the activation of safety sensors or confirmation signals from other system components. For example, the ball valve will only open if both a pressure sensor indicates sufficient pressure and a flow sensor confirms that the pipeline is clear. This safety mechanism prevents potential system failures or hazards by ensuring that all required conditions are satisfied before allowing the flow of fluid.

On the other hand, the **OR gate** provides flexibility in the control logic, allowing the ball valve to open if at least one of several conditions is true. For instance, the ball valve may be programmed to open if either a manual override button is

pressed or a specific sensor detects the presence of a material requiring transport. This arrangement enhances responsiveness in the system, allowing for quick adjustments to operational conditions. By integrating AND and OR gates into the control logic for the ball valve, the system achieves both safety and versatility, ensuring optimal performance while maintaining control over the fluid flow.

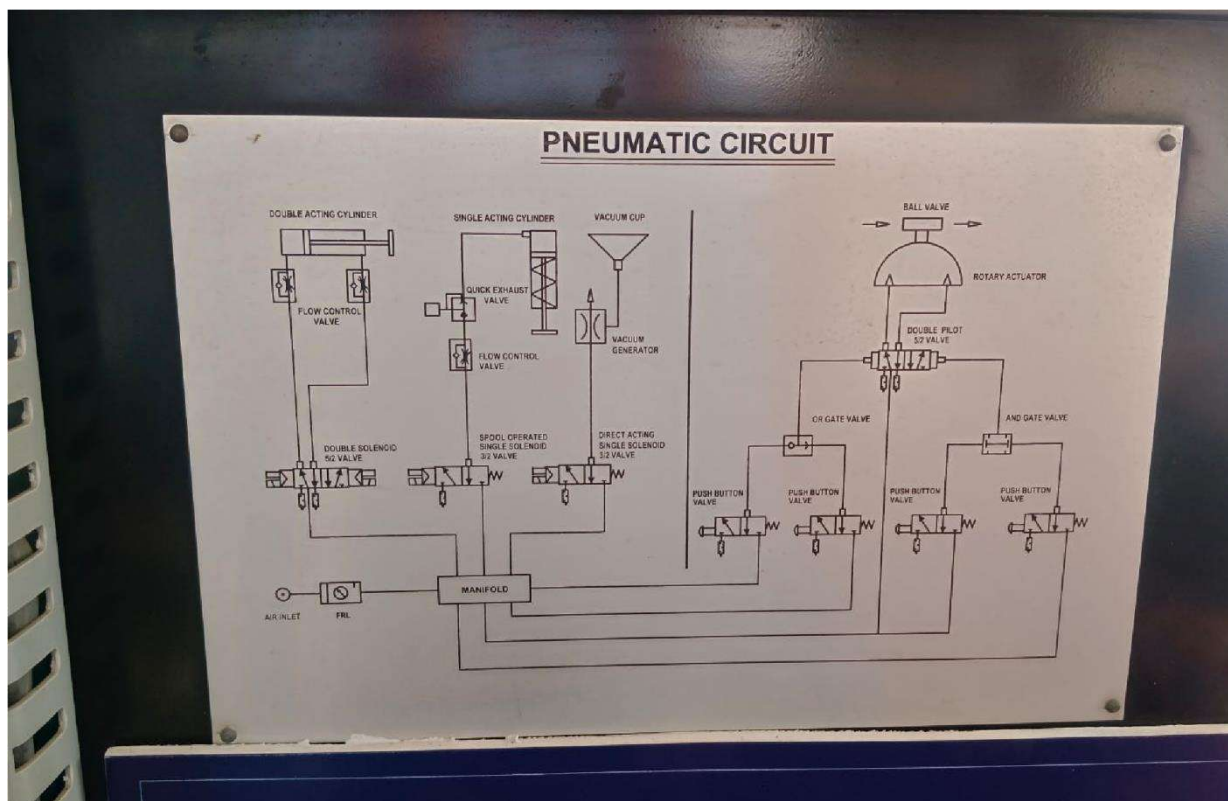

➤ **Pick and Place Operation**

In this project, the pick and place operation of sheets is achieved through the integration of vacuum cups, a vacuum generator, solenoid valves, and both single acting and double-acting cylinders. The process begins with the vacuum generator creating a vacuum, which is then transferred to the

vacuum cup attached to the end of Vacuum generator. The vacuum cup grips the sheet by creating a sealed area that generates sufficient suction to hold the sheet securely.

To initiate the pick and place operation, a solenoid valve is activated, allowing compressed air to flow to the single-acting cylinder. This cylinder extends, moving the vacuum cup down toward the sheet. As the vacuum cup makes contact with the sheet, the vacuum generator is activated, creating a suction force that securely grips the sheet. Once the sheet is lifted, the single-acting cylinder retracts, pulling the sheet upward and away from the surface. a spring return mechanism to return to its original position after the sheet is released.

After lifting the sheet, the double-acting cylinder moves horizontally to the desired location. Once in position, another solenoid valve is activated to release the vacuum, allowing the sheet to be placed onto the designated area. This coordinated action of the vacuum cup, vacuum generator, solenoid valves, and the cylinders ensures efficient and precise handling of sheets throughout the pick and place operation, optimizing the overall workflow in the automation process.

RESULTS AND DISCUSSIONS :

At this stage of the project, the focus has been on testing the pneumatic circuit components manually, as the PLC has not yet been integrated. The results from the manual operation of the system provided as detailed below:

1. **Ball Valve Operation with AND/OR Logic:** The ball valve, controlled manually through push-button valves and AND/OR gate logic, demonstrated reliable operation. The valve opened and closed as expected based on the input combinations, confirming the correct implementation of the logical gates. This manual testing validated that the ball valve's operation can be effectively controlled through simple logic conditions, laying the groundwork for future automation with the PLC. Once the PLC is connected, it will further enhance the system's functionality by automating the control logic.
2. **Vacuum Generator and Double-Acting Cylinder for Material Handling:** The integration of the vacuum generator with the double-acting cylinder was tested for material handling applications. The vacuum system was able to create sufficient suction to lift sheets, while the double-acting cylinder provided smooth and controlled movement of the material. This confirmed that the pneumatic components are well-suited for handling tasks. However, the next phase PLC integration will enable more precise and automated control over material movement, improving the overall efficiency and coordination of the vacuum and cylinder actions.

3. **Pneumatic Cylinder Operation:** The manual operation of both the double-acting and single-acting cylinders revealed smooth and consistent movement. The flow control valves and quick exhaust valves worked as intended, optimizing the speed of cylinder extension and retraction. This successful testing indicates that the pneumatic system is functioning properly under manual control, providing confidence that the cylinders will operate effectively once they are automated via PLC. The system will become more efficient and responsive when the manual operations are replaced with programmed logic, allowing for more complex motion sequences.

MODEL APPLICATIONS :

Educational Tool for Industrial Automation Training:

- Provides hands-on experience with pneumatic systems like cylinders, valves, and vacuum generators.
- Equips trainees with foundational skills for automation roles in industrial and mechatronics fields.
- Used in vocational schools and technical institutes to teach pneumatic circuit control and automation.

Skill Development in Pneumatic Circuit Design:

- Helps trainees learn to design and assemble pneumatic circuits for industrial applications.
- Focuses on configuring solenoid valves, flow controls, and actuators for practical use.
- Prepares trainees for roles in industries like manufacturing that rely on pneumatic systems.

Simulation of Real-World Material Handling Systems:

- Replicates systems used in packaging, logistics, and automotive industries for hands-on learning.
- Trains students in tasks like pick-and-place operations, sheet handling, and conveyor automation.
- Prepares trainees to operate and troubleshoot material handling systems in industrial settings.

Practical Training in Pneumatic Automation for Process Control:

- Teaches how pneumatic components are used to automate tasks in food, beverage, and pharmaceutical industries.
- Enables trainees to control pneumatic systems like presses and tools manually or with future PLC integration.
- Equips trainees to automate repetitive industrial tasks, improving efficiency and control.

Troubleshooting and Maintenance Skills for Pneumatic Systems:

- Provides knowledge on diagnosing and repairing pneumatic circuits in industrial settings.
- Helps trainees understand component functions and how to resolve issues like air leaks or faulty actuators.
- Prepares them to maintain systems in industries like automotive, aerospace, and heavy machinery.

Application in Safety Training for Pneumatic Systems:

- Teaches proper safety protocols, including managing air pressure and operating valves and cylinders.
- Ensures trainees know how to safely operate high-pressure pneumatic systems in industrial settings. Focuses on promoting safety standards in industries where pneumatic automation is common.

Automation Project Development and Testing Platform:

- Serves as a platform for trainees to develop and test automation projects using pneumatic devices.
- Prepares them for configuring and programming automated systems for industrial applications.
- Equips trainees with the skills needed for roles in robotics, material handling automation, and custom solutions.

CONCLUSION :

The pneumatic trainer kit successfully achieved the objective of providing practical experience in vacuum-based material handling using double-acting cylinders. Trainees learned how to control vacuum systems for tasks like lifting and moving materials, which are widely used in industries such as packaging and automotive. In the future, integrating PLC systems into this setup will enable full automation, allowing trainees to program and manage complex control logic, enhancing their understanding of automated material handling.

Through hands-on work, trainees gained valuable skills in designing and assembling pneumatic circuits, particularly in configuring solenoid valves, flow controls, and actuators. These skills are essential for industrial applications such as clamping, positioning, and fluid control. Expanding the kit to include more advanced pneumatic system designs, such as proportional control valves or pressure sensors, will expose trainees to more sophisticated systems found in high-tech manufacturing, further advancing their expertise. The kit also enabled trainees to automate ball valve control using AND/OR logic gates, reinforcing their understanding of automation in fluid control systems. This foundational knowledge is critical for industrial automation roles

REFERENCES

- [1] Hadi, H. H., & Sallom, M. Y. (2019). *Pneumatic Control System of Automatic Production Line Using SCADA Implement PLC. 2019 4th Scientific International Conference Najaf (SICN)*. doi:10.1109/sicn47020.2019.9019356
- [2] S. Pukkella, V. Suresh Babu, and K. Abubacker, "Design and Development of Pick and Place Arm Robot." Accessed: Oct. 21, 2024. [Online]. Available: <https://www.irjet.net/archives/V7/i8/IRJET-V7I8825.pdf>
- [3] Pastrascioiu, C., Popescu, M., & Stamatescu, S. (2018). *Teaching System for Pneumatic Actuators. 2018 10th International Conference on Electronics, Computers and Artificial Intelligence (ECAI)*. doi:10.1109/ecai.2018.867908
- [4] "How Do You Troubleshoot A Malfunctioning Pneumatic Valve? - Rowse Pneumatics," *Rowse-pneumatics.co.uk*, 2024. <https://www.rowse-pneumatics.co.uk/blog/post/how-do-you-troubleshoot-a-malfunctioning-pneumatic-valve?srsltid=AfmBOooCTT2gc5VkpvgеBJYmbW0R1F11rZkUmfCCYnWbSOVGWsnqMa3l> (accessed Oct. 21, 2024).

4. Display and Control of Fire Fighting Panel using Arduino

Name of Student: Kshirsagar Tejasvi Kadu

Shingane Dipali Chhagan

Deshmukh Kasturi Kashinath

Year: B.E. _2024-2025

Title: Display and Control of Fire Fighting Panel using Arduino

ABSTRACT :

A firefighting panel for pumping is a device used to pump water from a water source, such as a well or a municipal water supply, to a fire hydrant. The panel typically connected to the pump, a water tank, and a control panel that allows firefighters to activate the pump and control the flow of water. The panel is designed to provide a steady and reliable source of water for firefighting operations, and can be used in a variety of settings, including residential, commercial, and industrial areas.

It's essential for commercial fire safety systems and is used to start fire pumps in emergencies. The panel receives signals from alarm devices, like pressure-operated switches, sprinkler alarm valves, or remote fire alarm equipment. It then activates motor control devices to provide power to the fire pump motors and monitors the pump. The panel also monitors conditions that could prevent the fire pump from operating properly. It is needed to lift up the water from the ground level to the valves at some specific pressure with the help of pressure sensor.

INTRODUCTION :

1.1 Introduction of the Project Work

A firefighting panel for a pumping system is a critical component in fire protection and suppression systems. It serves as the control center for activating and managing the pumps that deliver water or other fire-suppressing agents to sprinkler systems, hydrants, or other discharge points in a building.

-

Fire pumps are essential components of a building's fire protection system, especially in high-rise structures. They're critical for distributing water through sprinkler systems where water pressure from water mains and firefighting equipment cannot reach.

Using Arduino for displaying and controlling a firefighting panel introduces a flexible, cost-effective approach to managing and monitoring fire pumps and associated components. Arduino can be used to handle sensor inputs, display critical parameters, and trigger actions based on predefined conditions, making it an ideal choice for customizing and enhancing the capabilities of fire pump control systems. Problem Statement

1.2 Problem Statement

In buildings and industrial facilities, firefighting systems are critical for safety, often relying on centralized control panels to manage fire pumps and ensure prompt response during fire emergencies.

Conventional firefighting panels are complex, and can be challenging to customize based on specific requirements. Moreover, monitoring parameters like ON, OFF status and real time data system alerts often requires multiple components, making integration and maintenance challenging.

1.3 Objectives

Develop an Arduino-based display and control system for a firefighting panel to offer a flexible, and reliable solution for managing fire pump operations. This system should monitor key parameters, automate responses, display real-time information, and allow manual control through a user-friendly interface.

1.4 Scope of the Project Work

The scope of the project includes:

1. System Design and Planning

Define the overall system architecture, including the components to be integrated, such as sensors, relays, displays.

2. Component Integration and Circuit Assembly

Assemble and connect all hardware components on a breadboard or PCB, following the circuit design.

3. Arduino Programming and Logic Implementation

Develop Arduino code to manage the system's core functions:

4. Real-Time Monitoring: Continuously read pressure sensor data and display it on the LCD.



Fig. 1.1: Fire Fighting Panel Connected to Pump

Control Panel: The technician or engineer is shown operating or checking the control panel, possibly using a mobile device or tablet to check system status or perform remote diagnostics.

Fire Pump Controller: This is mounted on the wall (above the main pump) and used to start or stop the fire pump manually, based on operational requirements.

Fire Pump: The large red pump in the center is the main fire pump. It supplies high-pressure water throughout the building's fire suppression system when activated during a fire event.

Jockey Pump: The smaller pump on the right side of the main pump is likely a jockey pump, which maintains

system pressure to prevent unnecessary operation of the main fire pump due to minor pressure drops or leaks.

1.5 Key Motivation for our project assignment

Fire Incident in Bhopal Gas Tragedy (1984) – Lack of Integrated Fire Fighting Panel

The Union Carbide India Limited (UCIL) chemical plant in Bhopal, India, was a pesticide manufacturing facility that housed large quantities of hazardous chemicals, including methyl isocyanate (MIC), a highly toxic and flammable gas. At the time of the incident in 1984, the plant was using basic fire safety measures, including manual fire alarms and water-based sprinklers, but it did not have an integrated, automated Fire Fighting Panel (FFP) that could manage fire detection, alarm systems, and suppression systems across different zones of the plant.

On the night of December 2-3, 1984, a major chemical leak occurred at the UCIL plant, where approximately **40 tons of methyl isocyanate gas** were released into the atmosphere due to a combination of faulty maintenance, poor safety practices, and operational failures. The gas leak resulted in a catastrophic toxic gas cloud that spread over the surrounding areas of Bhopal, causing the **Bhopal Gas Tragedy**, one of the world's worst industrial disasters.

While the direct cause of the gas leak was primarily due to a flawed storage tank and failure of safety systems, the plant's overall lack of automated fire fighting and emergency response systems contributed significantly.

Consequences of Not Having a Fire Fighting Panel:

1. **Massive Casualties and Environmental Damage:**
The **Bhopal Gas Tragedy** resulted in the deaths of over 3,000 people within the first few days, with estimates of total fatalities reaching up to 15,000 over time. Over **half a million people** were exposed to the toxic gases. The chemical leak also led to long-term health consequences for the affected population, including respiratory issues, birth defects, and neurological disorders.
2. **Spread of Fire and Chemical Reaction:** While the immediate tragedy stemmed from the toxic gas exposure, the absence of a proper fire fighting system meant that the fire risk escalated as well, especially as the chemicals interacted and created additional hazardous conditions.
3. **Economic and Operational Damage:** The plant suffered irreparable damage, including the destruction of machinery, storage tanks, and large portions of the facility. The **economic costs** of the incident, including legal settlements, fines, and compensation, were astronomical. UCIL's parent company, **Union Carbide Corporation**, faced substantial financial penalties, and the incident resulted in the permanent closure of the Bhopal plant.

4. **Environmental Contamination:** The gas leak not only caused immediate harm to humans but also severely contaminated the soil and water in the surrounding areas. The lack of firefighting systems that could have suppressed or contained hazardous material spills or fires contributed to the environmental damage.
5. **Long-Term Legal and Regulatory Fallout:** In the aftermath of the tragedy, UCIL faced legal action, both from the Indian government and from affected families. The company was found guilty of gross negligence, and the absence of proper fire safety measures and emergency response systems became a key point in the investigations. **Lessons Learned:**
 1. **The Importance of Fire Fighting Panels in Hazardous Environments:** The Bhopal Gas Tragedy highlighted the catastrophic consequences of not having an integrated and automated fire fighting panel in place. In high-risk industrial settings involving volatile chemicals and flammable gases, a fire fighting panel could have reduced response times, contained hazards more efficiently, and prevented the spread of fire or leaks.
 2. **Automated Fire Detection and Response:** An integrated fire fighting panel connected to gas detection, smoke, heat, and flame detectors could have provided immediate alerts and triggered automatic fire suppression systems in critical areas. In this case, it could have detected gas leaks early

and activated suppression systems to limit the spread of fire and reduce the explosion risk.

3. **Worker Safety and Emergency Protocols:** Fire fighting panels are not just about fire suppression—they also help to automate evacuation procedures, alert first responders, and ensure the safety of personnel in hazardous conditions. In Bhopal, the lack of such systems directly contributed to delays in evacuations and increased worker exposure to the toxic gas.

4. **Regulatory and Compliance Requirements:** The case underscores the need for strict compliance with industrial fire safety regulations, particularly in hazardous industries. Today, modern plants are required to have integrated fire safety systems, including fire fighting panels, to ensure both personnel and environmental protection.

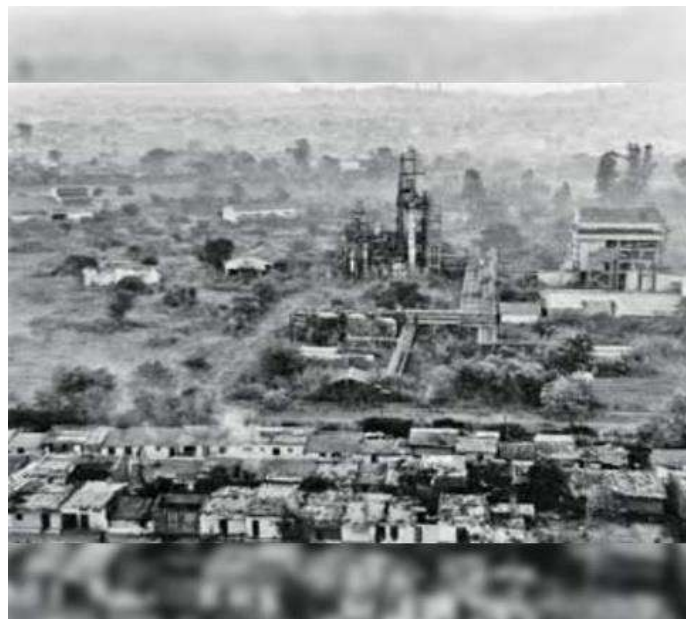

Literature Review

2.1. Introduction :

Firefighting systems require efficient and reliable control and monitoring of pumping operations to ensure effective fire suppression. Arduino microcontrollers have gained popularity due to their flexibility, scalability, and cost-effectiveness.

Review of Existing Literature

1. The study presents a system using Arduino Uno, sensors, and relays to control pumps and display system status on an LCD [5].
2. This research integrates Arduino Uno, sensors, and GSM modules for remote monitoring and control of pumps [6].
3. This paper proposes a system using Arduino Mega, sensors, and a web-based interface for real-time monitoring and control.
4. This study presents a basic firefighting system using Arduino Uno, sensors, and actuators to control pumps

The above references concludes that they used

Sensors like Pressure sensor and Temperature sensor

- Arduino microcontrollers (Uno, Mega)

- Pump control algorithms (ON/OFF)

- Display units (LCD)

Communication protocols (GSM, Wi-Fi, IoT)

- Actuators (relays, valves)

Challenges and Future Directions :

- Improving system reliability and accuracy
- Integrating multiple sensors and actuators
- Enhancing user interface and experience
- Exploring machine learning and AI applications
- Ensuring scalability and compatibility

Project Work:

The methodology for developing a control and display system for a firefighting panel focused on pumping operations involves several critical steps, including system design, selection of components (sensors, relays), Arduino programming, display integration, and testing. This system is designed to monitor environmental conditions, and automatically activate a water pumping system.

Component Selection and Circuit Setup :

Micro-controller (Arduino): Choose an Arduino model with sufficient I/O pins, such as Arduino Uno or Mega, to accommodate all sensors and control components. Relays control enabling the Arduino to switch the pump on or off based on fire conditions.

Display Modules:

LCD Display (e.g., 16x2 or 20x4): Displays real-time sensor readings, system status, and fire alerts.

Arduino Programming

Sensor Data Collection: Program the Arduino to read data from each sensor and convert these readings to meaningful values. For instance.

Control Mechanisms for Pump Activation

Relay Control: Use a relay to manage the water pump's operation. The Arduino will send signals to the relay, which will act as a switch to power the pump.

Display Logic:

Program the LCD to show the status of the pump (e.g., ON or OFF) and indicate if the system is active.

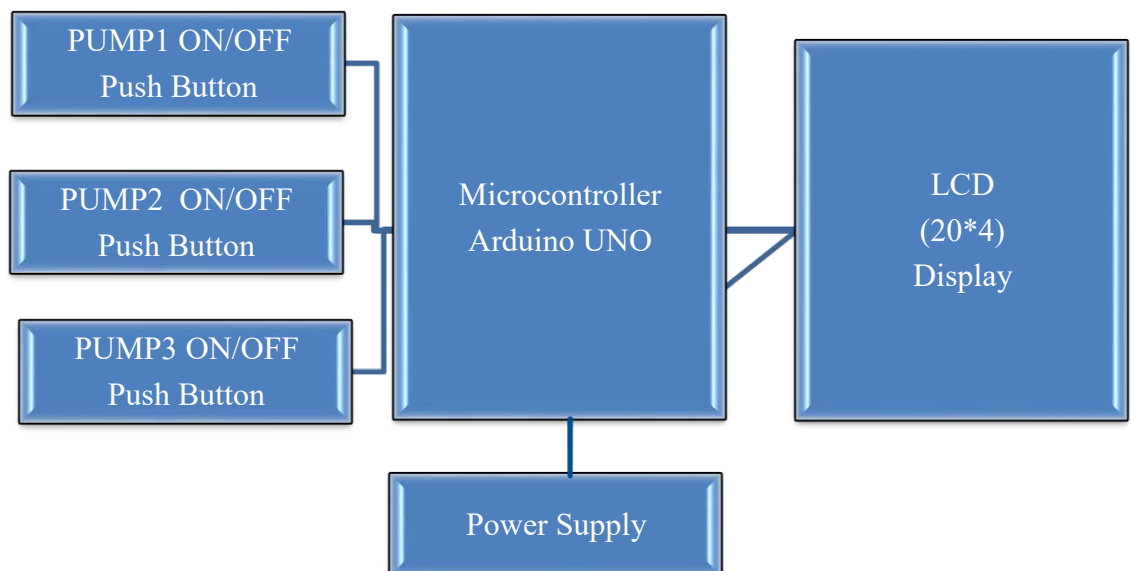

Figure 3.1: Block Diagram Interface of Arduino with Digital Display and Push Buttons

In the block diagram of an Arduino-based system designed to control three pumps via push buttons, with a 20x4 LCD display for status monitoring.

Push Buttons are Used to toggle ON/OFF states for three pumps(PUMP1, PUMP2, and PUMP3).

Microcontroller of Arduino Uno serves as the core processing unit, interfacing with the push buttons and the LCD.

A 20x4 LCD display module shows the operational status or feedback of the pumps.

Power Supplies necessary power to the system components.

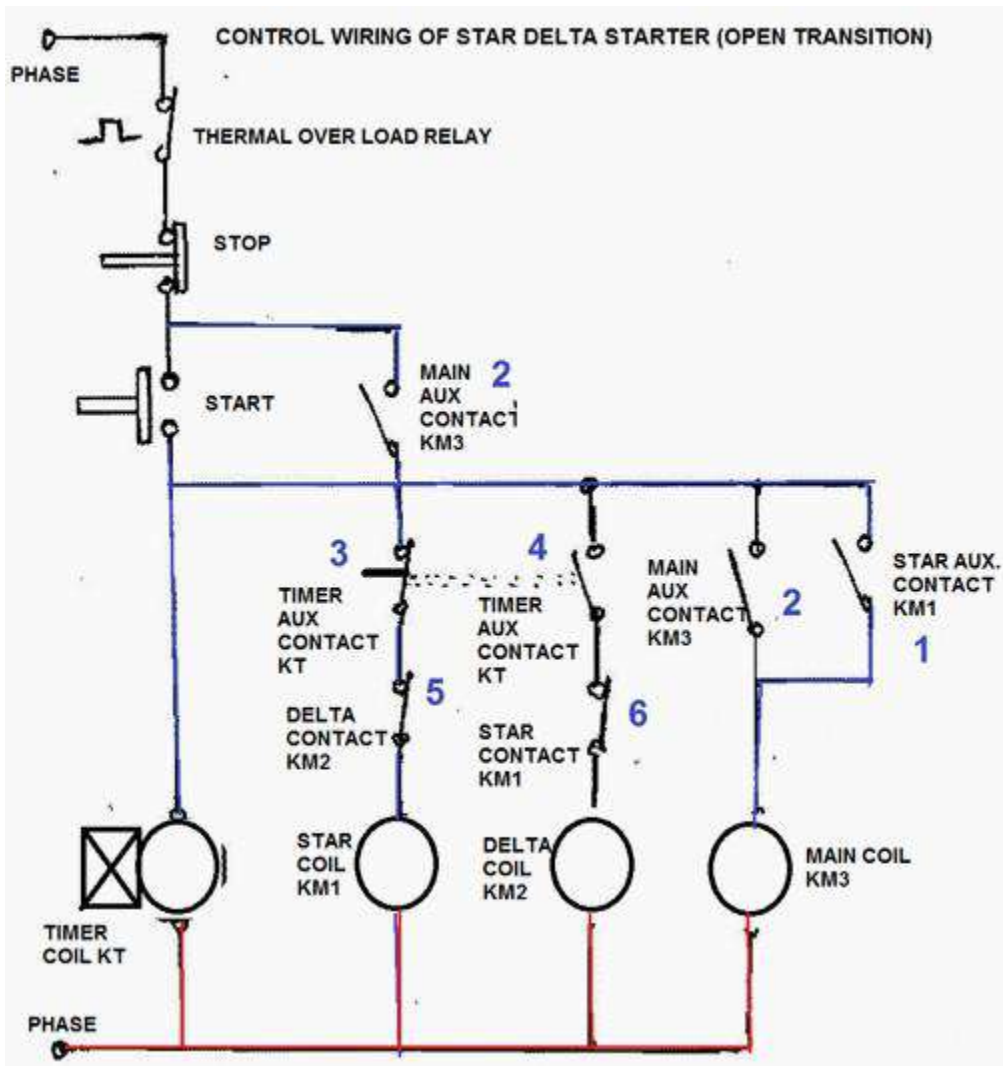

Figure 4: Control Diagram of Star-Delta Starter

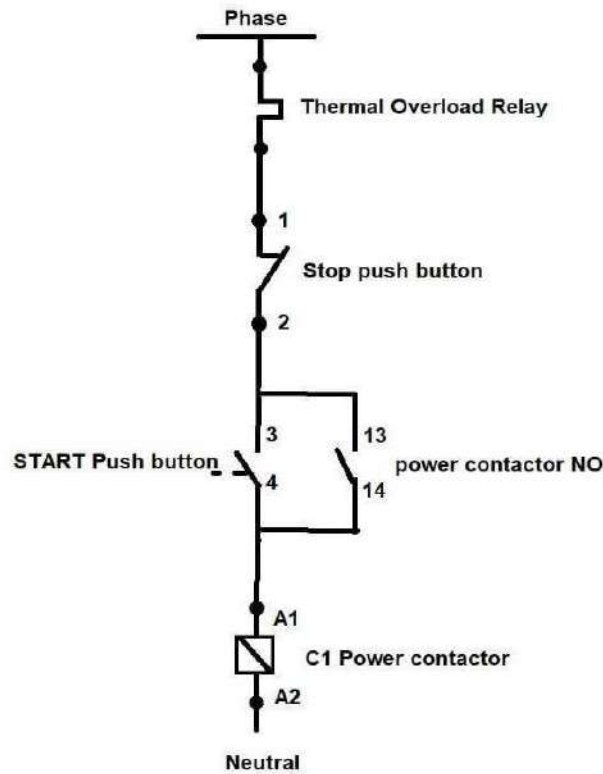

Figure 4.2: Control Diagram of DOL Starter

CONCLUSION :

The development of a control and display system for a firefighting panel using Arduino provides an efficient, cost-effective solution for automated fire detection and suppression. Through the integration of various sensors (smoke, temperature, and flame), the Arduino-based system can detect early signs of fire, activate a water pump for fire control, and alert occupants with real-time displays and alarms. This setup offers significant advantages over traditional systems, especially in terms of affordability, ease of customization, and adaptability to specific environmental needs. This Arduino-driven approach proved to be both reliable and scalable, making it suitable for small to medium-sized facilities that

require robust fire safety measures. Additionally, the system's capability for remote monitoring, using GSM or Wi-Fi modules, adds an extra layer of security by enabling off-site response, which is especially valuable for facilities without continuous human presence.

In conclusion, the Arduino-based firefighting panel for pumping operations is a promising alternative to conventional fire control systems, combining essential features like automation, real-time display, and remote alerting with a simple, modular design. This solution highlights Arduino's potential to create effective, accessible safety systems that can be tailored to a wide range of applications.

REFERENCES :

- 1) International Journal of Research Publication and Reviews, Vol 3, no 4, pp 389399, March 2022
- 2) International Journal for Research in Applied Science & Engineering Technology
(IJRASET) ISSN: 2321-9653; IC Value: 45.98; SJ Impact Factor: 6.887 Volume 7
Issue III, Mar 2019- Available at www.ijraset.com
- 3) Shinde, S. S., et al. "Automated Fire Fighting System Using Arduino and Pump Control." International Journal of Engineering Science and Computing 8.4 (2018): 13250-13255.
- 4) International Journal of Trend in Scientific Research and Development (IJTSRD) International Open Access Journal ISSN No: 2456 – 6470 |

- 5) www.ijtsrd.com | Volume – 2| Issue - 5 SMS Alarm System for Weather Station using Arduino and GSM.
- 6) Kumar, R. R., et al. "Arduino Based Fire Fighting System with Automated Pump Control." *International Journal of Advanced Research in Electrical, Electronics and Instrumentation Engineering* 6.3 (2017): 1556-1563.
- 7) Al-Garni, M. A., et al. "Design and Implementation of Fire Fighting Pump Control System Using Arduino and GSM." *International Journal of Advanced Science and Technology* 28.4 (2019): 111-120.
- 8) Liu, J., et al. "Development of Arduino-Based Fire Fighting System with Pump Control and Monitoring." *Journal of Sensors and Sensor Systems* 9.2 (2020): 266274.
- 9) Shinde, S. S., et al. "Automated Fire Fighting System Using Arduino and Pump Control." *International Journal of Engineering Science and Computing* 8.4 (2018): 13250-13255.

5. MART ELEVATOR BY LAB VIEW

Name of Student: Hetali Pankaj Baviskar

Year: B.E. _2024-2025

Title: Smart Elevator by Lab View

ABSTRACT :

This project presents a Smart Elevator system, designed using NI LabVIEW software, to address both hygiene and operational efficiency requirements in modern infrastructure. In response to health concerns such as COVID-19, this system incorporates touch-free button functionality through the use of proximity sensors. These sensors allow passengers to select floors without physically pressing buttons, significantly reducing contact surfaces and mitigating the risk of germ transmission in high-traffic areas. By ensuring minimal physical interaction, the system provides a hygienic solution, particularly valuable in hospitals, offices, and residential buildings where cleanliness is paramount.

To enhance the efficiency and reliability of elevator operations, this project also integrates Programmable Logic Controllers (PLCs) for synchronized communication between two parallel elevators. The PLCs enable real-time data sharing and coordination, allowing the elevators to dynamically adjust to demand patterns. This results in an optimized distribution of passenger load, minimized wait times, and improved energy efficiency. Additionally, the system's capability for intelligent inter-elevator communication provides enhanced service continuity in case of

increased usage or one elevator being offline for maintenance. Overall, the Smart Elevator project showcases an innovative application of automation in building management, prioritizing both user health and efficient vertical transport. This design is not only adaptable to various building layouts but also highlights how technology can address public health challenges while meeting modern demands for operational excellence.

INTRODUCTION

1.1 Introduction of the Project Work

The smart elevator project aims to enhance safety, convenience, and efficiency in modern buildings. Traditional elevators, while functional, often lack hygiene focused features, particularly crucial in environments where infection control is essential, such as during the COVID-19 pandemic. This project leverages NI LabVIEW software and PLC-based systems to design a smart elevator with proximity sensors that enable touch-free controls, reducing the need for physical contact. Additionally, the system supports inter-elevator communication for optimal operation, ensuring faster and more organized movement of passengers across different floors. The **Smart Elevator** designed using **NI LabVIEW** combines advanced features to enhance convenience, efficiency, and hygiene. Below are the essential components and working principles of such a system:

Features:

1. **Touch-Free Buttons:** Utilizes proximity sensors to allow passengers to select floors without physical contact. Reduces the risk of transmitting pathogens, making it ideal for health-conscious environments (e.g., post-COVID scenarios).

2. **Parallel Elevator Communication:** Two elevators work in tandem, managed by a Programmable Logic Controller (PLC). Optimizes elevator usage by coordinating movement, reducing waiting times, and increasing energy efficiency.
3. **User-Friendly Interface:** Built in LabVIEW, the interface is intuitive, displaying real-time elevator status and floor selection options. Includes visual indicators such as floor numbers, direction arrows, and door status.
4. **Safety Features:** Emergency stop and alarm functionalities. Door obstruction sensors to prevent accidents.
5. **Energy Efficiency:** Integrates smart scheduling algorithms to optimize energy usage based on traffic patterns.

1.2 Problem Statement

Conventional elevator systems face multiple challenges, such as hygiene risks due to shared buttons, lack of seamless communication between parallel elevators, and inefficient resource utilization. These limitations became especially evident during the COVID-19 pandemic, where minimizing touchpoints became critical. This project addresses these challenges by developing a smart elevator system with proximity-based, touch-free controls and an efficient PLC-based communication system that allows for coordinated operation between multiple elevators.

1.3 Objectives

- To create a touch-free elevator interface using proximity sensors to minimize contact and enhance hygiene.

- To design an efficient communication system between parallel elevators using PLC, allowing them to work in synchronization.
- To utilize NI LabVIEW software for real-time monitoring and control, ensuring reliable and responsive system performance.
- To reduce wait times for users by implementing intelligent algorithms that allow elevators to prioritize and direct movement based on demand.

1.4 Scope of the Project Work

This project focuses on developing a smart elevator prototype with the following features:

- Proximity sensors for touch-free floor selection, minimizing physical contact.
- PLC-based communication for effective inter-elevator coordination, aiming to improve efficiency in buildings with multiple elevator shafts.
- A user-friendly interface designed in NI LabVIEW that displays real-time elevator status and controls.
- Scalability for deployment in high-rise buildings, hospitals, malls, and other public spaces where hygiene and efficiency are priorities.

LITERATURE REVIEW

2.1 Introduction

The development of smart elevators has gained significant attention due to the need for efficient, hygienic, and intelligent vertical transportation systems. The integration of LabVIEW into smart elevator designs offers advanced monitoring, control, and simulation capabilities. This review examines existing studies, innovations, and trends related to smart elevators implemented using LabVIEW.

2.2 Literature pertaining to topic

Smart elevator systems integrated with LabVIEW exemplify the advancement of vertical transportation by leveraging technology to enhance efficiency, safety, and user experience. LabVIEW, a graphical programming platform known for its versatility, plays a crucial role in enabling real-time control, simulation, and data acquisition for these systems. Proximity sensors connected via LabVIEW enable touch-free button operations, addressing hygiene concerns and improving usability in public spaces. Additionally, energy efficiency is achieved through LabVIEW's capability to incorporate predictive algorithms that optimize elevator deployment based on traffic patterns, minimizing energy consumption and reducing operational costs. Hardware-in-the-loop (HIL) testing using LabVIEW ensures thorough validation of elevator models in a simulated environment, significantly lowering development costs and risks before physical implementation. The platform's integration with

PLCs also supports the parallel operation of multiple elevators, synchronizing their movement to reduce wait times in high-traffic scenarios. Furthermore, LabVIEW enables developers to design prototypes and simulate critical functions such as speed control, door mechanisms, and emergency responses, offering a flexible and scalable approach to system development. These features highlight LabVIEW's significant contribution to creating intelligent, usercentric, and energy-efficient smart elevator systems.

2.3 Concluding remarks on literature review

The integration of LabVIEW into smart elevator systems enhances control, efficiency, and user experience. Proximity sensors, real-time data processing, and multi-elevator coordination are significant advancements enabled by LabVIEW.

METHODOLOGY USED :

NI LabVIEW (Laboratory Virtual Instrument Engineering Workbench) is a graphical programming environment developed by National Instruments (NI). It is widely used for designing, testing, and controlling complex engineering and scientific systems. LabVIEW provides a user-friendly interface with drag-and-drop functionality to create block diagrams representing logic and data flow, making it particularly effective for tasks like data acquisition, hardware control, real-time monitoring, and simulation. LabVIEW is popular in industries such as automation, robotics, and aerospace, as well as in academia for research and teaching purposes. It supports integration with hardware devices like DAQ systems, PLCs, and Compact RIO controllers, allowing

seamless interaction between software and physical components. With its flexibility and extensive library of prebuilt functions, LabVIEW simplifies the development of sophisticated applications, including smart systems like elevators, machinery diagnostics, and IoT devices.

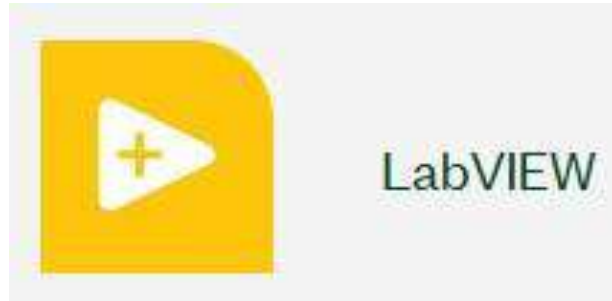

Fig. 1.1: NI LabVIEW Logo

In NI LabVIEW, the **Front Panel** and **Block Diagram** are two key components for building applications.

1. **Front Panel:** The front panel is the user interface of the application, where controls (like buttons, sliders, and knobs) and indicators (like LEDs, graphs, and text displays) are placed. Users interact with the front panel to input data, monitor results, and control processes visually.
2. **Block Diagram:** The block diagram contains the underlying code for the application, represented in a graphical, dataflow format. Here, LabVIEW uses "wires" to connect functions, structures, and nodes, allowing data to flow from one element to another.

DESIGN OF SMART ELEVATOR USING LABVIEW :

4.1 Front Panel

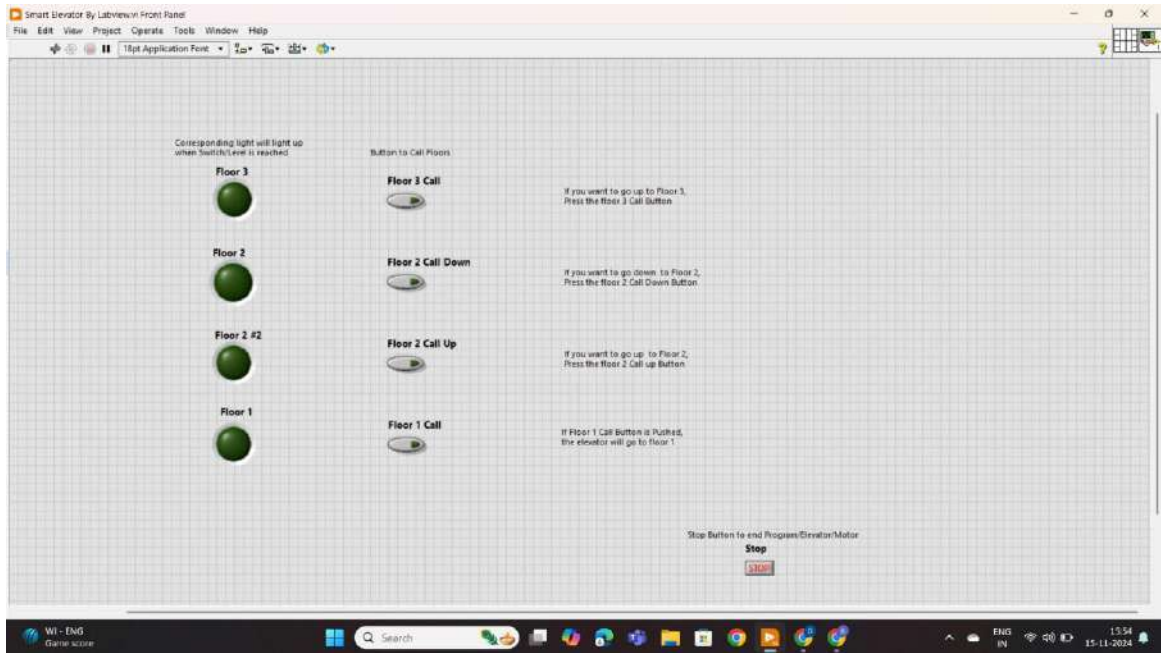

Fig. 1.2: Front Panel of Smart Elevator Project

This front panel in NI LabVIEW is designed as the user interface for a smart elevator system simulation. Here's a breakdown of its components:

1. **Floor Indicators:** Circles labelled as "Floor 1," "Floor 2," and "Floor 3" light up when the elevator reaches a corresponding floor.
2. **Call Buttons:** Buttons for calling the elevator to each floor, labelled as "Floor 1 Call," "Floor 2 Call Up/Down," and "Floor 3 Call." Each button allows the user to simulate calling the elevator to specific floors.
3. **Instructions:** Text descriptions guide users on what each button does, such as pressing "Floor 3 Call" to move the elevator to the third floor.
4. **Stop Button:** A "Stop" button at the bottom allows users to terminate the program, halting the elevator simulation.

This interface provides users with control and feedback elements to simulate a real-world elevator system, allowing interaction and testing of basic elevator functionalities.

4.2 Block Diagram

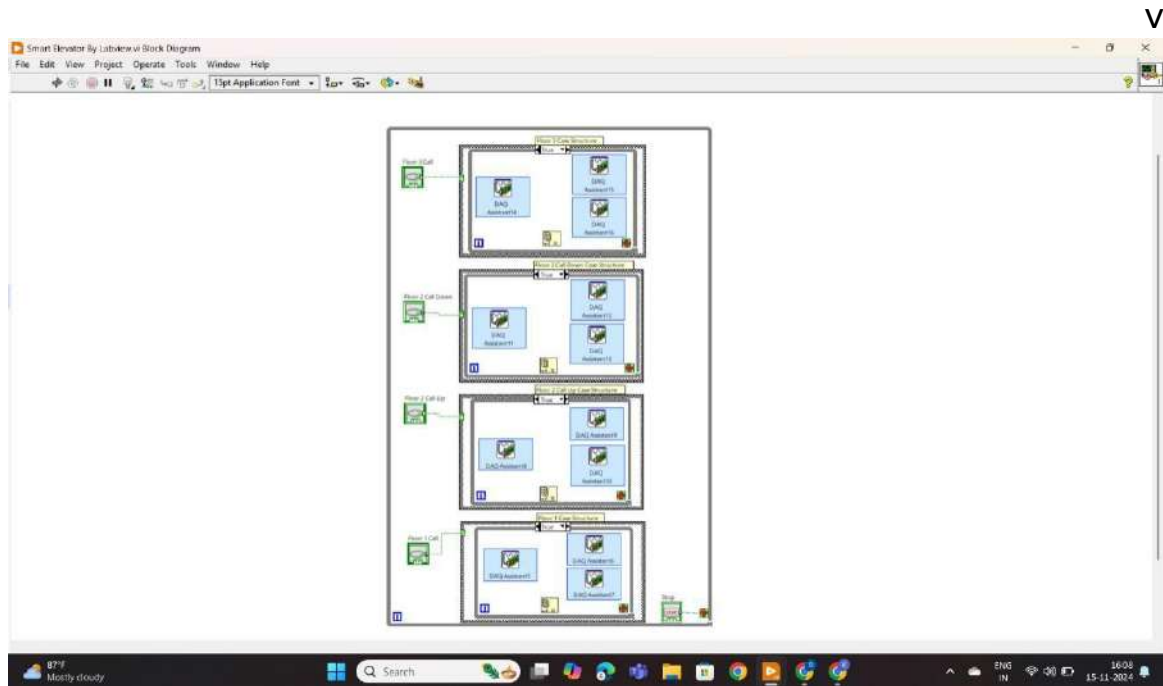

Fig. 1.3: Block Diagram of Smart Elevator Project

This LabVIEW block diagram for the smart elevator project shows the logic for controlling elevator movement between floors. Here's an overview of its structure:

1. **Case Structures:** Each floor (Floor 1 Call, Floor 2 Call Up/Down, and Floor 3 Call) has a designated case structure to handle elevator responses. The "True" cases are triggered when a call button is pressed for a specific floor, initiating the elevator's movement.
2. **DAQ Assistants:** Each case contains multiple "DAQ Assistant" blocks, responsible for data acquisition and control signals to interact with hardware components

(sensors, motor controllers, etc.). These allow the program to control the elevator's movements, stopping at the requested floor.

3. **Stop Button:** At the bottom right, the "Stop" button halts the program, terminating the elevator's operation.

This setup enables the elevator to respond to floor calls efficiently, simulating the behavior of an actual elevator system by using NI LabVIEW's data acquisition and control capabilities. The block diagram manages the elevator's up and down movements based on user inputs, facilitating smooth transitions between floors

CASE STUDY :

One real-life case study of a smart elevator system involves Nayar Systems, a company specializing in telecommunications and Industrial IoT solutions for the elevator sector. Nayar Systems implemented a smart communication solution to address European safety standards for elevator emergency calls, particularly the EN81-28 standard. These standard mandates that elevators be equipped with a two-way communication system, allowing users to connect with emergency services in the event of a failure or entrapment. The system also requires periodic test signals to ensure the communication equipment is functioning correctly, sending an automated signal every 72 hours.

Nayar Systems' solution uses the Alai Secure technology, which ensures robust, encrypted communication between the elevator and the control centre, safeguarding against potential cybersecurity threats. This system operates across a wide network, with installations in 31 countries, and demonstrates how IoT and telecommunications can enhance elevator safety and reliability. Such smart systems have helped modernize the elevator industry by providing continuous connectivity, real-time diagnostics, and streamlined emergency response, thus minimizing downtime and improving user safety.

FUTURE SCOPE :

The future of smart elevators is set to revolutionize the way we experience vertical transportation, driven by advancements in technology, sustainability, and user-centric design. As buildings become smarter, elevators will be integrated into broader IoT (Internet of Things) ecosystems, allowing them to communicate with other systems like HVAC, lighting, and security. This integration will optimize energy usage, improve operational efficiency, and enhance the overall user experience. Predictive maintenance powered by IoT and sensors will allow smart elevators to detect potential issues before they occur, reducing downtime and minimizing maintenance costs.

Artificial intelligence (AI) and machine learning will play a crucial role in improving elevator operations. By analyzing real-time data, AI will optimize elevator routes, reduce waiting times, and improve traffic flow within buildings. Over time, smart elevators will learn from user behavior, predicting peak usage times and adjusting routes accordingly to further enhance efficiency. Voice and gesture recognition, along with facial scanning, will enable touchless interaction, improving hygiene and accessibility for all users, including those with disabilities. These technologies will also create more personalized experiences, with elevators adapting to the preferences of frequent users.

In terms of sustainability, smart elevators will incorporate energy-efficient technologies, such as regenerative drives, which capture and reuse energy during operation. This reduces energy consumption, lowers costs, and contributes to eco-friendly building practices. Biometric authentication, like fingerprint or retina scans,

will offer secure access to restricted floors, while integration with real-time surveillance systems will increase passenger safety.

As cities become smarter, smart elevators will be part of a larger, interconnected transportation ecosystem. They will communicate with autonomous vehicles, shared mobility systems, and other smart infrastructure, creating a seamless urban mobility experience. Overall, the future of smart elevators will be defined by greater efficiency, sustainability, security, and user convenience, transforming how we move within buildings and cities.

CONCLUSION:

In conclusion, developing smart elevators using LabVIEW offers a powerful platform for creating efficient, reliable, and advanced elevator systems. With LabVIEW's capabilities in data acquisition, real-time monitoring, and control systems, it enables seamless integration of features like proximity sensors, touchless interfaces, and predictive maintenance. Through its user-friendly graphical programming environment, LabVIEW allows for rapid prototyping and the creation of customized solutions for controlling elevator functions, enhancing energy efficiency, and ensuring safety. The integration of PLCs for communication between elevators and sensor-based systems further improves operational reliability and user experience. As LabVIEW continues to evolve, it will remain a key tool in the development of smart elevators, helping to meet future demands for intelligent, automated, and sustainable vertical transportation solutions.

REFERENCES

- [1] **Carlos F. Nicolás, Ikerlan**, "Model-Based Design for Elevator HIL Test System"
- [2] Publisher: IEEE- Jun Ye, Haiyang Hu; Zhen Wang; Ranran Sheng, "Design of Model Elevator Control System Based on NI CompactRIO and LabVIEW."
- [3] **Carlos F. Nicolás, Ikerlan**, "Smart Elevator Applications for Energy Efficiency"
- [4] <https://www.mvnonation.com/resource/case-study%3A-nayar-systems'-smartelevator--->
- [5] <https://www.amplicon.com/products/ni-labview-software/>

6. A PID BASED TANK MANAGEMENT SYSTEM

Name of Student: Neha Kailas Adhav

Akash Somnath Bodke

Parth Ramchandra Muley

Year: B.E. _2024-2025

Title: A PID Based Tank Management System

ABSTRACT:

The fluid level in tanks is controlled in numerous production processes, both on land and onboard. The ship complex contains systems of fuel tanks, oil tanks, and ballast tanks, which ensure the stability of the ship, and which have different amounts or levels of liquid that need to be controlled. Measuring liquid levels in tanks is a necessary process due to the maritime and transshipment characteristics of the liquid during navigation. Most traditional measuring systems were designed and implemented using sophisticated hardware devices, making them expensive, with low functionality, and limited precision. The introduction of the concept of virtual instrumentation has led to greater flexibility in creating a more adaptable measurement system. The paper presents a simulation of the liquid level control system in a ship tank using a PID controller to maintain a defined liquid level.

The tank's liquid level control simulation is performed in the LabVIEW software package. To illustrate the flexibility of the

designed system, the front panel of the developed virtual instrument is shown. This simulation is an excellent opportunity for students to practice in the field of process measurements and instrumentation and marine automation (application of various methods for setting the PID controller). After working on such and similar simulation models, they prepare in the best way for their future professional careers.

INTRODUCTION :

1.1 Introduction of the Project Work:

In any process industry, the different process variables are maintained at the desired values by the operation of the different manual and automatic control loops in order to obtain the high-quality products at lesser cost along with all the safety aspects of the plant operation. The PID controller is one of the most important components of any automatic control loop. With the advancement of the industrial revolution, computer acts an important role. Nowadays computer simulation is widely used for industrial process control design to show the eventual real effects of alternative conditions and courses of action. The PID algorithm can be designed using many computers programming language such as C, MATLAB etc. But we have used the National Instrument's LabVIEW. LabVIEW (short for Laboratory Virtual Instrumentation Engineering Workbench) is a platform and development environment for a visual programming language. The reasons for selecting the LabVIEW simulation software rather than the other one

are its Graphical User Interface and the speed of operation. The other benefits are the extensive support for accessing instrumentation hardware for interfacing, includes a compiler that produces native code for the CPU platform i.e. the graphical code is translated into executable machine code by interpreting the syntax and by compilation, with a large number of functions for data acquisition, signal generation, mathematics, statistics, signal conditioning, analysis, etc., and allows code reuse without modifications for sub-VIs

In this present paper, we have designed the PID algorithm with the help of this software language. By changing the input step signal the output characteristics curves are observed on the waveform chart. Based on the well-known tuning method, Ziegler Nichols method, the PID controller is tuned and the best value for K_P , K_I , K_D is determined. Using this PID algorithm we are able to control any continuous process variable.

1.2 Problem Statement

Develop A PID Based Tank Management System to maintaining optimal fluid levels which is crucial for operational efficiency, safety, and product quality.

1.3 Objectives:

1.3.1 Maintain Optimal Fluid Levels:

Ensure precise control of fluid levels in tanks to prevent overflows and shortages, enhancing safety and operational efficiency.

1.3.2 Enhance System Response:

Develop an adaptive PID control algorithm that can quickly respond to dynamic changes in process conditions, reducing response times and improving system stability.

1.3.3 Real-time Monitoring and Control:

Implement real-time data collection and monitoring capabilities to provide operators with instant access to tank conditions, enabling timely decision-making.

1.3.4 Energy Efficiency Optimization:

Optimize the PID control parameters to minimize energy consumption during fluid management processes, aligning with sustainability goals and reducing operational costs.

1.3.5 Predictive Maintenance:

Incorporate predictive analytics to foresee maintenance needs and reduce unplanned downtimes, leading to smoother operations and lower maintenance costs.

1.3.6 Integration with IoT and Analytics:

Ensure seamless integration with IoT devices and advanced analytics platforms for enhanced data analysis.

1.3.7 User-friendly Interface:

Design an intuitive human-machine interface (HMI) that allows operators to easily monitor and control tank systems, facilitating quick adjustments and reducing training time.

1.3.8 Regulatory Compliance:

Ensure that the system meets industry standards and regulations for safety and environmental impact, minimizing risks associated with fluid management.

1.3.9 Scalability and Flexibility:

Design the system to be scalable and adaptable to different tank sizes and types, allowing for widespread application across various industries.

LITERATURE REVIEW :

2.1 Introduction

2.1.1 Fundamentals of PID Control:

Definition and Structure: Discuss the Proportional, Integral, and Derivative components, including their roles and contributions to system stability and performance.

Mathematical Representation: Explain the mathematical formulation of the PID controller and its transfer function.

2.1.2 Tuning Methods:

Classical Tuning Techniques: Review traditional methods like Ziegler-Nichols, Cohen-Coon, and trial-and-error approaches.

Modern Tuning Techniques: Explore advanced methods such as model-based tuning, genetic algorithms, and optimization techniques.

2.1.3 Performance Metrics:

Response Characteristics: Discuss key performance indicators (KPIs) such as rise time, settling time, overshoot, and steady-state error.

Robustness and Stability: Review the concepts of stability margins and robustness in PID control.

2.1.4 Applications in Industry:

Case Studies: Summarize examples of PID controller applications in various industries, such as chemical processing, HVAC systems, and robotics.

Challenges and Solutions: Highlight specific challenges faced in real-world implementations and the solutions proposed in the literature.

2.1.5 Integration with Other Control Strategies:

Hybrid Control Approaches: Discuss the combination of PID with other control strategies, such as fuzzy logic, neural networks, and adaptive control.

Comparative Studies: Review studies that compare the performance of PID controllers with other control methods.

2.1.6 Simulation and Modeling Tools:

Software Tools: Evaluate the use of simulation tools like MATLAB/Simulink for modeling and analyzing PID control systems.

2.1.7 Recent Trends and Innovations:

Emerging Technologies: Explore recent advancements in PID control, such as the use of digital controllers and IoT integration.

Research Gaps: Identify areas in the literature that require further exploration or improvement.

2.1.8 Conclusion and Future Directions:

Summary of Findings: Conclude with a summary of the key insights gained from the review. Future Research

Opportunities: Suggest potential areas for future research and development in PID control.

2.1.9 References and Key Contributions:

Compile a list of seminal works, key authors, and recent studies that have significantly contributed to the field of PID control.

METHODOLOGY :

3.1 Introduction

Data acquisition is a process of collecting information from the observed environment. The measurement and acquisition system consists of: the acquisition, analysis and presentation of data. In order to transfer data from measuring devices for further processing and display, a direct connection of measuring devices to a computer is used. The concept of virtual instrumentation has been very present in recent years in measuring technology, and refers to the transition from traditional hardware measuring devices to modern software-oriented measuring systems. Virtual instrumentation is a term that refers to the integration of hardware and software, including the processes of measurement, acquisition, processing and display of data. Due to the growing complexity of engineering, the need for a large number of specialized and expensive instruments and software, as well as the need for highly qualified personnel to work with these instruments, virtual instrumentation has become a trend in technology and science. The purpose of a virtual instrument is identical to the function of a classic instrument, and the difference is that a virtual instrument can be changed and adjusted unlike a classic instrument that has a fixed functionality specified by the manufacturer. The presentation of data is most often in the graphical form, functions and controls of the graphical interface, which in their appearance resemble

real measuring instruments. Virtual instrumentation programs allow the user to implement a device that will best suit his requirements, or specific purpose. LabVIEW software together with the appropriate hardware enables the realization of a complete measurement and acquisition system. Virtual instruments have found applications in various fields One of them is the measurement and control of levels in ship tanks. Each ship, depending on its structure, has different tanks, such as fuel, oil and ballast tanks. Measuring liquid levels is often the key to the safe and reliable operation of the ship and it is necessary to measure, check and regulate the amount of liquid in the ship's tank on a daily basis. It is necessary to respect the procedures related to the functioning of the ship's tank, because otherwise, on the one hand, the environment would be endangered, and on the other hand, there would be problems with stability. Due to advances in measurement technology, instead of manual measurements, there is an automatic control system that allows continuous monitoring and regulation of fluid levels. In the example of the simulation presented in this paper, a PID controller was used, which is very often used in the process industry.

3.2 METHODOLOGY

3.2.1 PID controller design:

Certain control laws characterize the automatic control system (SAU). This law represents the mathematical dependence based on which the control device processes the relevant (input) signals and generates appropriate control actions. The most common form of such a control device is called a regulator. Closed feedback system control is shown in Figure 3.1

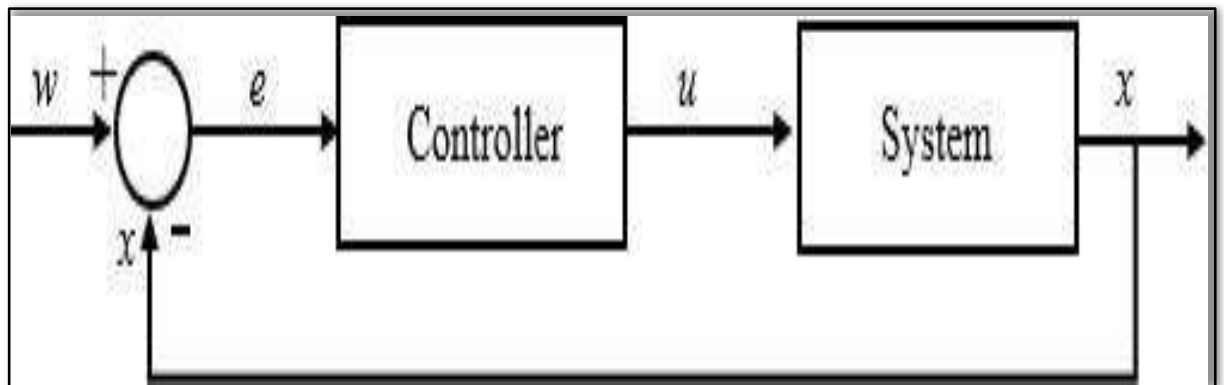

Figure 3.1: Closed feedback system control

PID controller has different applications in the regulation of industrial processes. The PID controller has three components, where "P" means proportional control action, "I" means integral control, and "D" means differential control action. The PID controller has the property that its integral member increases the accuracy of the system in the steady-state and the differential member increases the speed. Therefore, a suitable choice of PID controller parameters will be able to influence the overall behavior of the system in both transient and stationary modes.

The realization of the PID controller is shown in Fig. 2. The error signal is the input of the controller e and the input of the actuator is the output of the controller u .

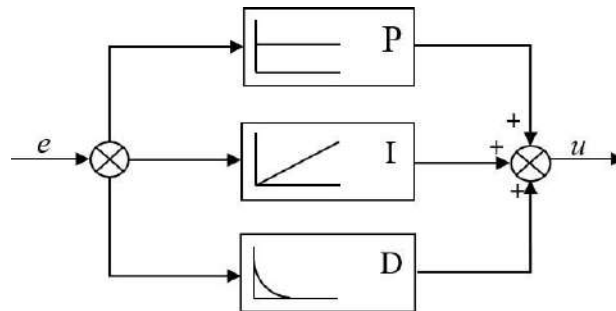

Figure 3.2. Block diagram of PID controller

3.1.1 Mathematical model of the system:

The tank system with one inlet and one outlet is shown in Fig. 3. An appropriate mathematical expression can be written for such a tank, which connects the input flow of the tank q_{in} with the output flow q_{out} .

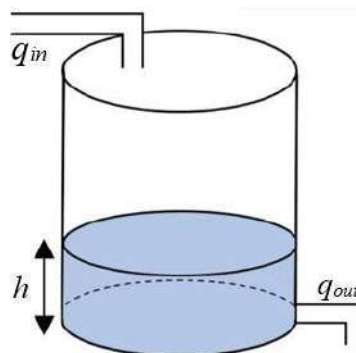

Figure 3.3 Tank system with one inlet and one outlet

The simulation of liquid level control in a tank with one inlet and one outlet was determined according to a mathematical model.

In this model, it is assumed that the density of the liquid at the inlet, outlet and in the tank is the same and that the tank has flat vertical walls. Using the balance equation given by relation (2):

$$A \frac{dh}{dt} = q_{in} - q_{out}$$

The level of the observed liquid tank can be obtained from equation (2) by a simple procedure:

$$h = \int \frac{1}{A} (q_{in} - q_{out}) dt$$

The velocity of fluid flow through the pipe at the bottom of the tank is given by the Bernoulli equation:

$$q_{out} = a \sqrt{2gh}$$

CONSTRUCTION :

3.1 Software system design and simulation:

Using a simple PID controller, physical parameters can be easily controlled with an appropriate mathematical model. Figure 3.4 shows the front panel of the tank liquid level control system. Using the set point, define the desired liquid level in the tank. During the simulation, this set tank level value can be changed at any time. PID parameters can also be set. The graph from the front panel Figure 4 shows the system status control. The block diagram of the liquid level control system is shown in Figure 3.5.

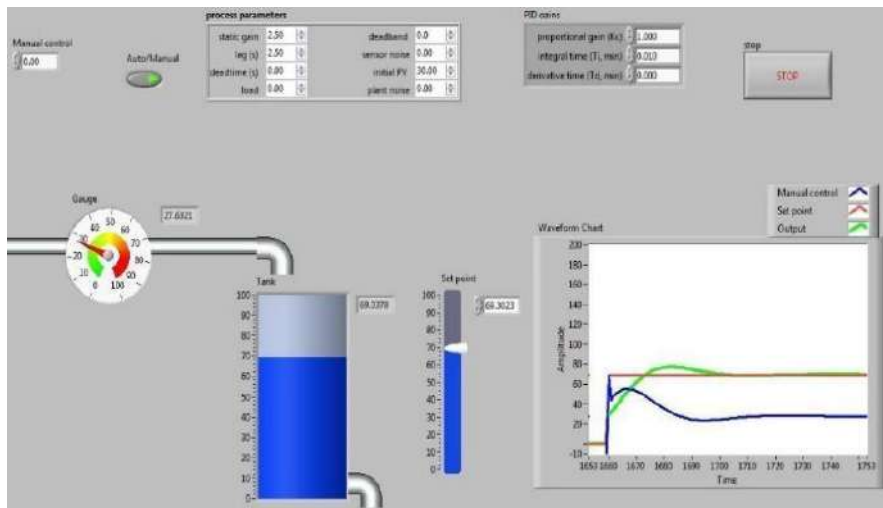

Figure 3.2.1: Liquid level control front panel

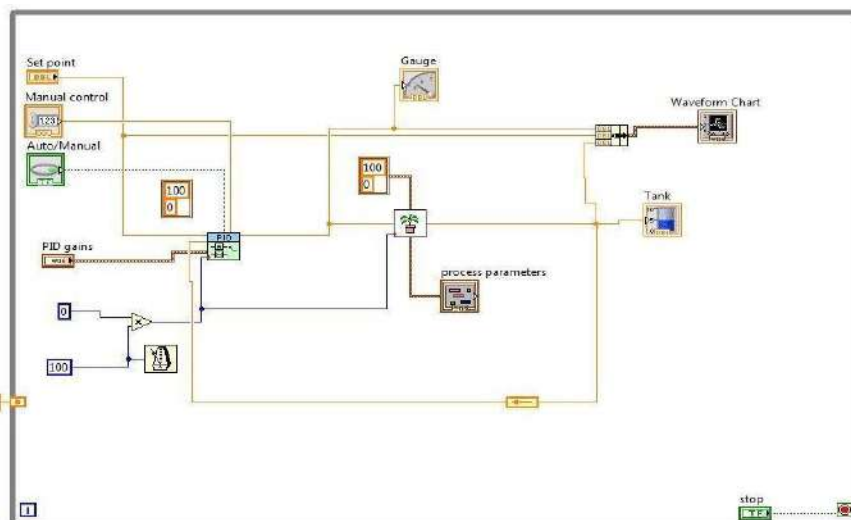

Figure 3.2.2. Block diagram liquid level control

A PID controller with advanced optional features shown in Figure 3.6, is implemented by using a PID algorithm. The advanced PID algorithm combines all of the features of the PID VI algorithm, plus manual mode control with bump less manual-to-automatic transitions, nonlinear integral action, two- degree-of-freedom control, and error-squared control. The Plant System VI shown in Figure 3.7, is a simulator created by National Instruments in order

to demonstrate the capacity of the PID system, replacing in some way the power part of the system (NI 2021).

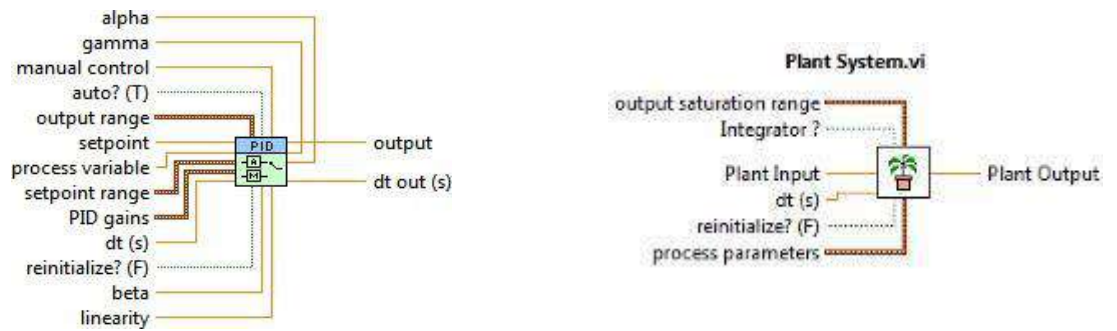

Figure 3.2.3: PID VI algorithm

3.3 Working

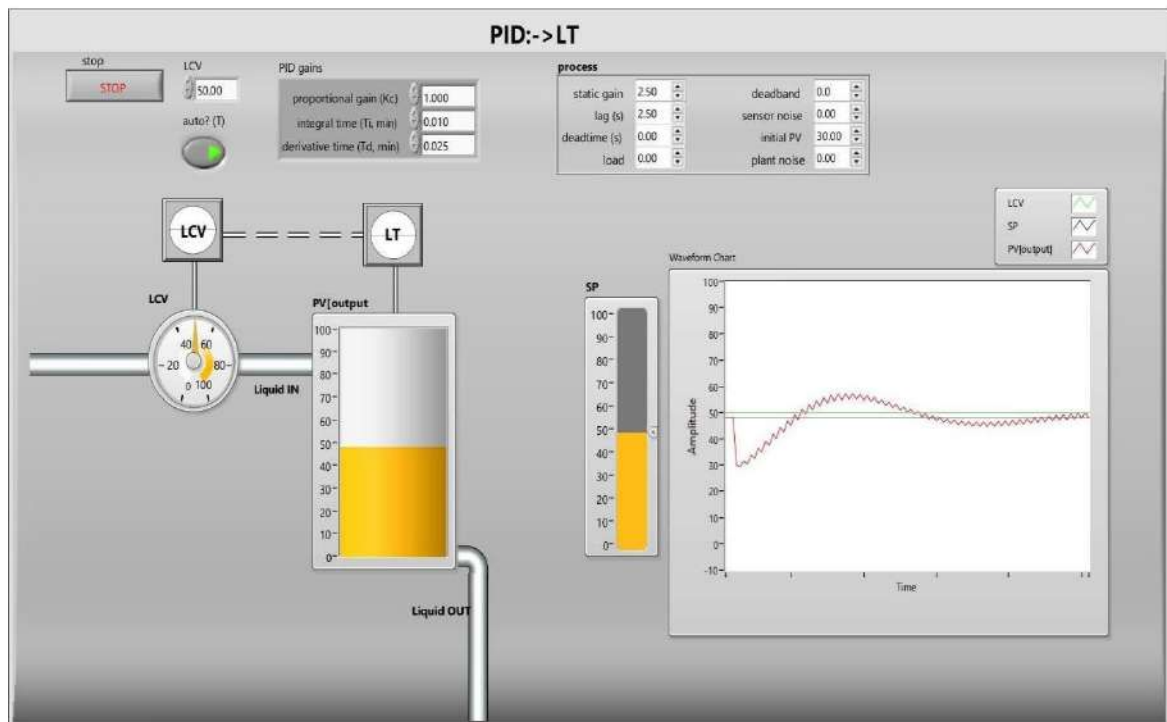

Figure 3.3.1: Working of PID controller in tank level system

3.1.1 Working of PID controller:

A PID (Proportional-Integral-Derivative) controller is commonly used for managing the level of liquid in tanks to maintain a desired set point. Here's how it works in a tank level management system:

Components of PID Controller

1. Proportional (P):

- The proportional component addresses the current error. If the tank level is below the desired set point, the controller increases the output to the pump. Conversely, if the level is too high, the output decreases
- Formula: The proportional output is calculated as:

$$P=K_p \times e(t)$$

- Where K_p is the proportional gain and $e(t)$ is the error at time t .

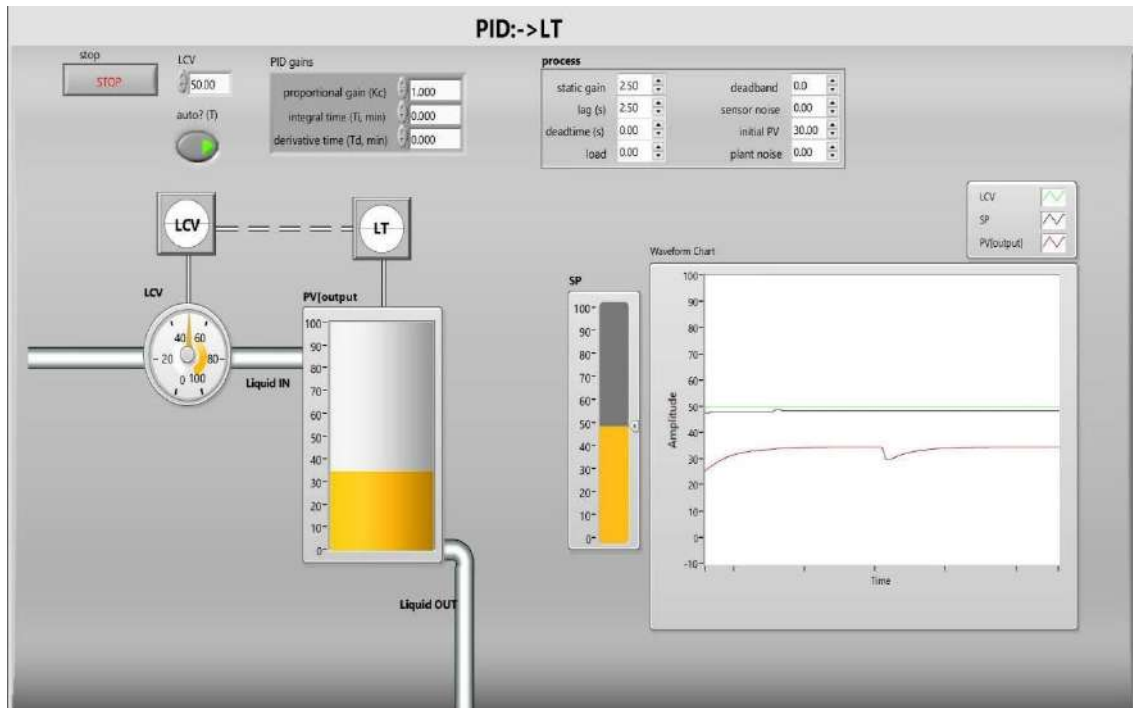

Figure 3.3.2: Working of P controller in tank level system

2. Integral (I):

- The integral component accumulates past errors over time, helping to eliminate the residual steady state error that occurs with a pure proportional controller.
- Formula: $I=K_i \int e(\tau) d\tau$ ○ Where K_i is the integral gain.

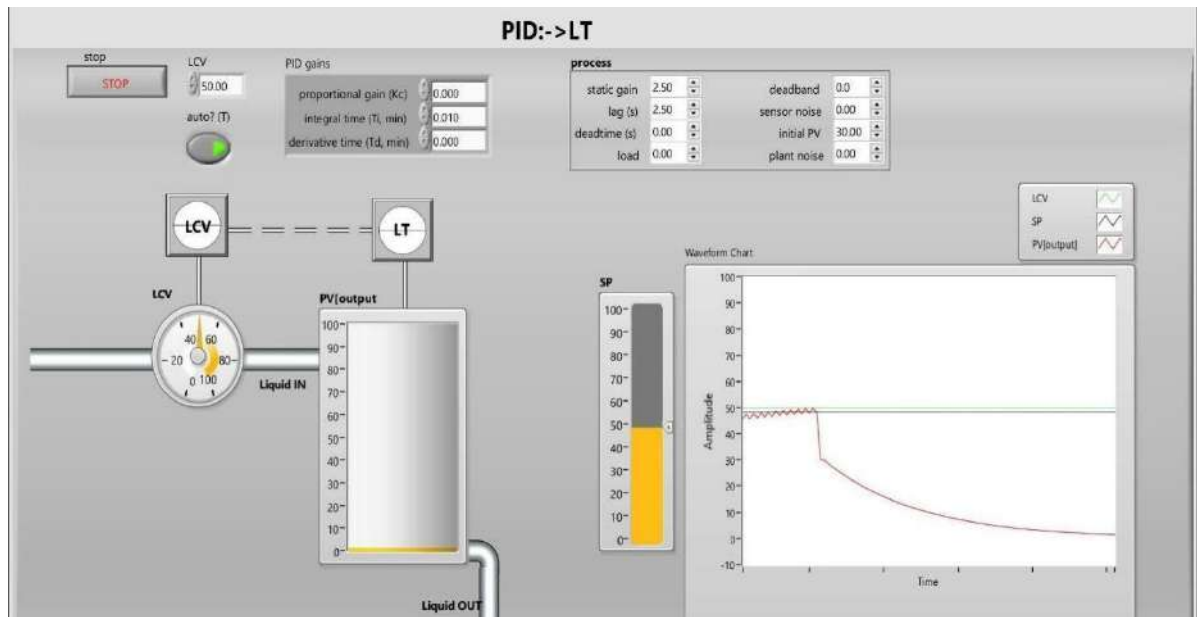

Figure 3.3.3: Working of I controller in tank level system

3. Derivative (D):

- The derivative component predicts future errors based on the rate of change of the error, which helps to dampen the system and improve stability.
- Formula: $D = K_d \cdot \frac{de(t)}{dt}$ Where K_d is the derivative gain.

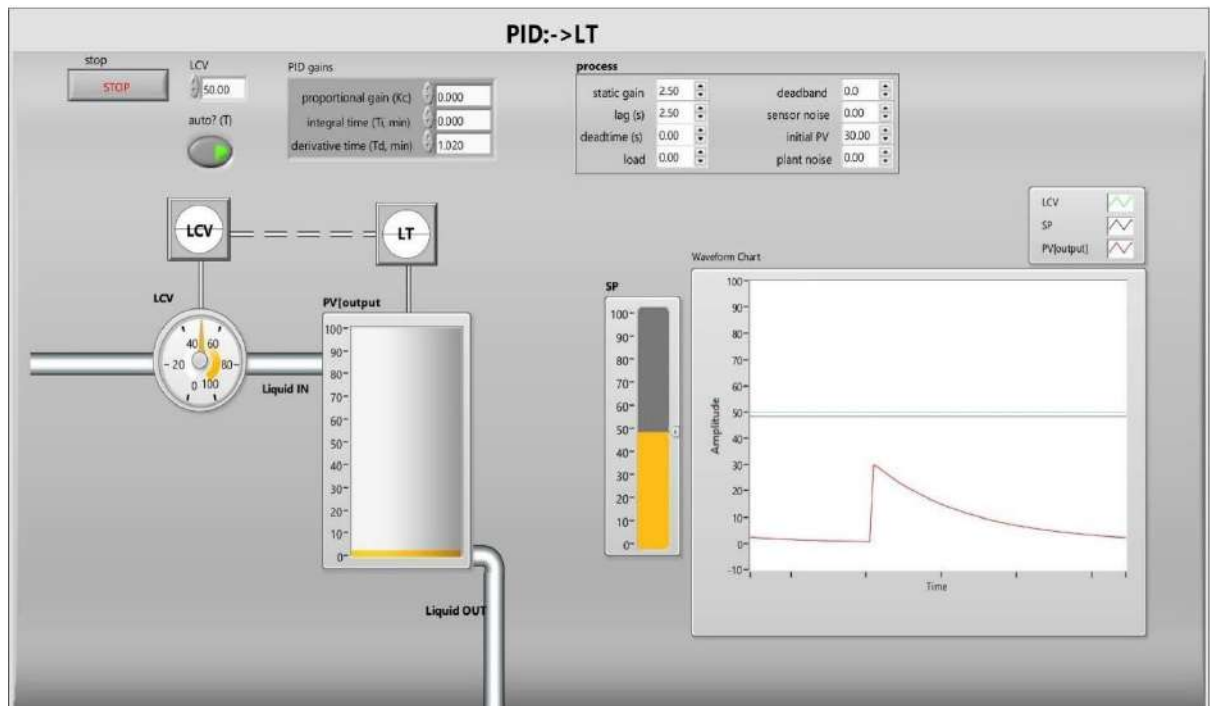

Figure 3.3.4: Working of D controller in tank level system

PID Controller Combinations

1. PI Controller :

A PI controller combines proportional and integral control to manage the tank level. Here's how it works:

- o Error Calculation:

The system continuously measures the tank level and calculates the error:

$e(t) = \text{Setpoint} - \text{Measured Level}$

- o Pid calculation:

The PI controller computes the output : $\text{Output} = K_p \cdot e(t) + K_i \int_0^t e(\tau) d\tau$

- o Actuation: The output is used to control a pump or valve. If the tank level is below the setpoint, the controller activates the pump; if above, it may open a drain valve.

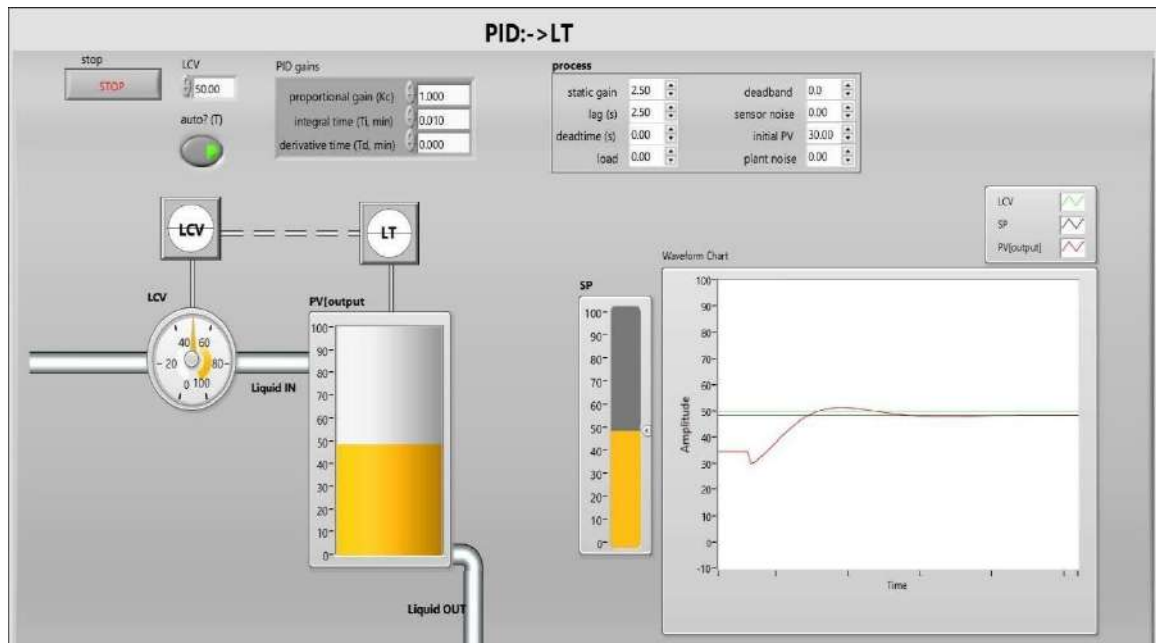

Figure 3.3.5: Working of PI controller in tank level system

2. PD Controller :

A PD controller combines proportional and derivative control, focusing on the rate of change of the error. Here's how it works: Error Calculation:

- o Error Calculation: As in the PI controller, calculate the error:
 $e(t) = \text{Setpoint} - \text{Measured Level}$
- o Pid calculation:

The PD controller computes the output : $\text{Output} = K_p \cdot e(t) + K_d \cdot (de(t)/dt)$

- o Actuation: The output is used to control the pump or valve, similar to the PI controller.

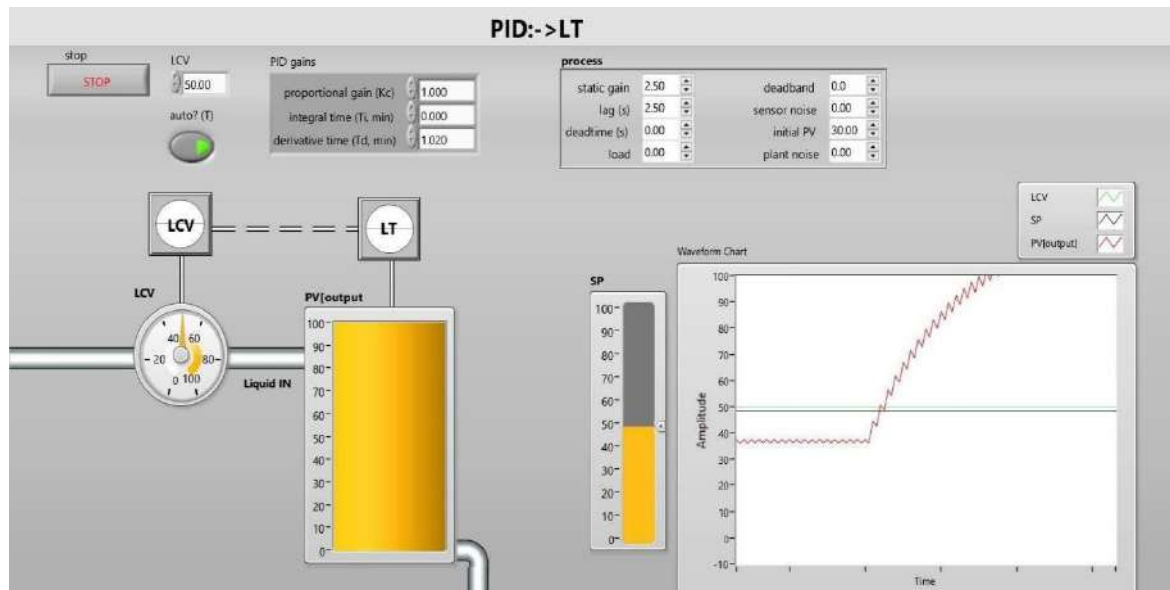

Figure 3.3.6: Working of PD controller in tank level system

3. PID Controller :

- o Error Calculation: The PID controller continuously calculates the error $e(t)$ between the setpoint and the process variable.
- o Pid calculation:

The PID controller computes the output : $Output = K_p \cdot e(t) + K_i \cdot \int e(\tau) d\tau + K_d \cdot (de(t)/dt)$

- o Actuation: The controller sends the computed output to the system, adjusting the process variable toward the setpoint.

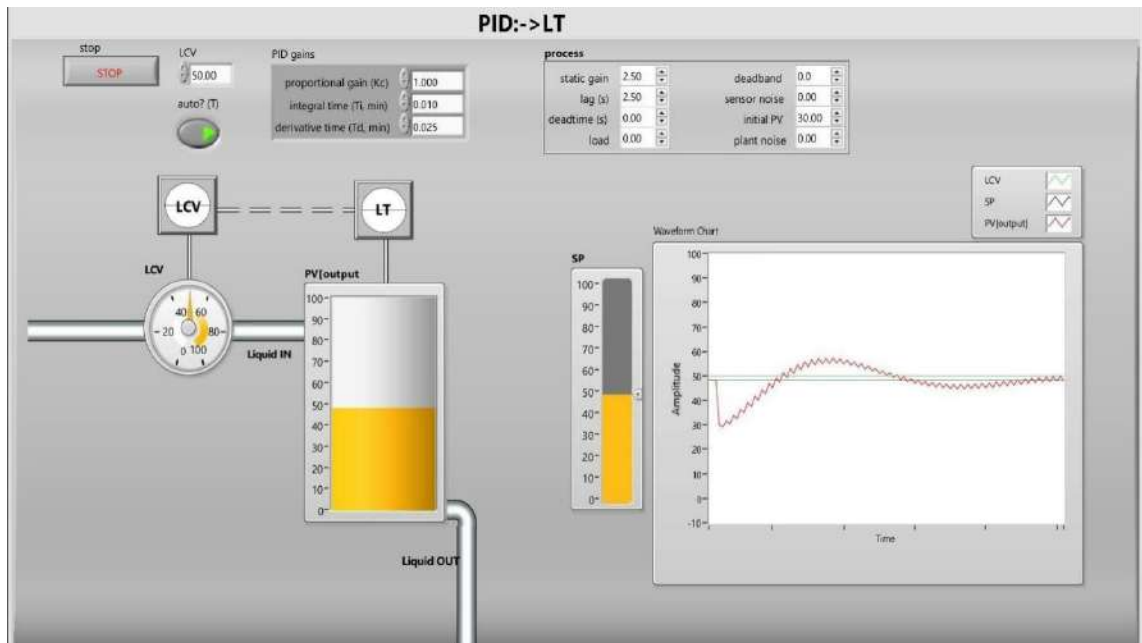

Figure 3.3.7: Working of PID controller in tank level system

4. PID Controller for Interacting tanks:

In an interacting tank system, the tanks influence each other. Changes in the level of one tank can affect the levels in adjacent tanks due to shared connections or flow paths.

- Error Measurement :

Each tank has its own PID controller, however it also needs to account for the influence of the neighboring tank.

- Cooperative Control: The PID controllers may need to work together, sharing information about their states. For example, if Tank A's level affects Tank B, the PID controller for Tank B may adjust its setpoint based on Tank A's output.
- Decoupling Techniques: In some cases, decoupling strategies are employed to minimize the interaction effects. This can

involve modifying the control algorithms or using additional control loops.

- PID Calculation: Each tank's PID controller will still compute its control action based on its own error, but it must also consider the interdependencies. For instance, if Tank A is filling and Tank B is draining, Tank B's PID controller must account for how Tank A's inflow might affect its level.
- Control Action: The PID controllers adjust the inflow and outflow for each tank, ensuring stability and maintaining the desired liquid levels across the system while considering the interaction.

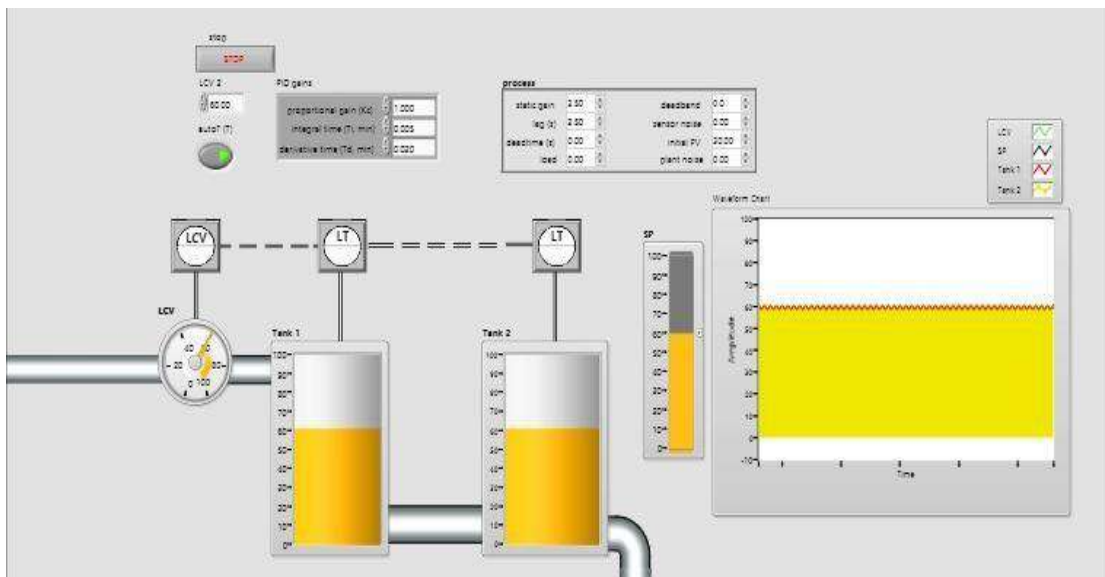

Figure 3.3.8: Working of PID controller for interacting tanks level system

5. PID Controller for Non-Interacting tanks:

In a non-interacting tank system, the tanks operate independently, meaning that the control of one tank .

Each tank has its own PID controller. The controller measures the error between the desired level (setpoint) and the actual level of liquid in the tank. ○ PID Calculation:

Proportional (P): The controller calculates the proportional response based on the current error. If the tank is underfilled, the output will increase to allow more inflow.

Integral (I): If there's a persistent error (e.g., the tank is consistently underfilled), the integral term accumulates this error over time and increases the output to correct it.

Derivative (D): If the liquid level is changing rapidly (either increasing or decreasing), the derivative term reacts to the rate of change to prevent overshooting the desired level.

- o Control Action: The PID controller adjusts the inflow or outflow valves based on the computed output, maintaining the liquid level at the desired set-point. Decoupling Techniques: In some cases, decoupling strategies are employed to minimize the interaction effects. This can involve modifying the control algorithms or using additional control loops.

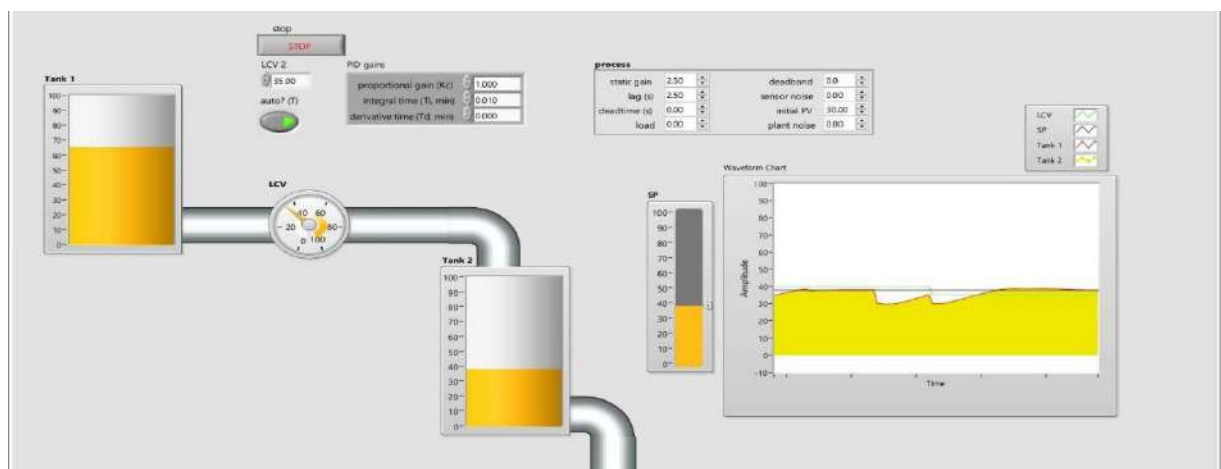

Figure 3.3.9: Working of PID controller for Non-interacting tanks level system

APPLICATIONS :

- 5.1 For temperature control loop in Distillation column
- 5.2 For controlling dryers & pumps in Sewage
- 5.3 For Vehicle Testing and Diagnostics in Automotive
- 5.4 For monitoring and controlling electrical
- 5.5 For testing semiconductor devices in Semiconductor Manufacturing
- 5.6 For testing avionic systems, navigation and communication in Aerospace
- 5.7 For testing the performance and reliability in Automated Test Equipment (ATE)
- 5.8 For continuous monitoring of patient in Biomedical Industry

FUTURE SCOPE :

The future scope of PID (Proportional-Integral-Derivative) based tank management systems in industry is promising, driven by advancements in technology and the growing need for automation and efficiency. Here are several key areas where PID systems are likely to evolve and expand:

6.1 Automation and Smart Manufacturing: As industries move towards Industry 4.0, PID controllers will be integrated with IoT devices for real-time monitoring and control, enhancing automation and reducing human intervention.

6.2 Data Analytics and AI Integration: Incorporating machine learning algorithms can optimize PID tuning and predictive maintenance, allowing for smarter and more adaptive tank management systems.

6.3 Energy Efficiency: PID systems can be fine-tuned to minimize energy consumption in processes, aligning with sustainability goals and reducing operational costs.

6.4 Scalability: PID systems can be designed to easily scale up or down, making them suitable for various tank sizes and types across different industries, from food and beverage to petrochemicals.

6.5 Remote Monitoring and Control: Enhanced connectivity will enable remote management of tank systems, allowing operators to monitor and adjust processes from anywhere, improving response times and safety.

6.6 Integration with Renewable Energy Sources: As industries adopt renewable energy, PID systems can help manage tanks in hybrid setups, ensuring stable operations even with fluctuating energy sources.

6.7 Regulatory Compliance and Safety: Advanced PID systems can incorporate safety protocols and real-time compliance checks, ensuring that operations meet industry standards and regulations.

6.8 Customization and Flexibility: Future PID systems may offer more customization options to cater to specific industry needs, allowing for tailored solutions that improve performance and efficiency.

6.9 User-friendly Interfaces: Developments in human-machine interfaces (HMIs) will make PID-based systems more accessible, enabling operators to manage complex processes intuitively.

6.10 Cross-industry Applications: The principles of PID control can be applied to various industries beyond traditional manufacturing, such as agriculture, pharmaceuticals, and water treatment, broadening the scope of tank management solutions.

CONCLUSION :

In the ship's system, it is extremely important to maintain control of the liquid level in various tanks, such as fuel tanks. Given the daily consumption, the process of controlling the fuel level in the tanks is extremely important for the safety of navigation. This paper presents the control and regulation of liquid tank levels. The concept of virtual instrumentation was used, where the appropriate simulation was done in the LabVIEW software. The liquid level in the tank was monitored using a simple PID controller. This simulation provides students with valuable experience in the fields of measurement and instrumentation process, as well as marine automation.

REFERENCES :

1. Abdul, Latheef, M.M. Shinu, Clint Augustine, and Rahul Antony. 2015. "LabVIEW Based PID Controller for Cylindrical Tank Level Controlling" 2 (4): 90-92. <https://doi.org/10.17148/IARJSET.2015.2421>.
2. Bajramović, Nikola. 1999. *Automatic u Brodest*. Kotor: Fakultet za pomorstvo, Univerzitet Crne Gore.
3. Barjamović, Nikola. 2006. *Brodska Mjerenja*. Kotor: Fakultet za pomorstvo, Univerzitet Crne Gore.
4. Conway, Jon, and Steve Watts. 2003. *A Software Engineering Approach to LabVIEW*. Prentice Hall Professional.
5. Jerome, Jovitha. 2010. *Virtual instrumentation using LabVIEW*. PHI Learning Pvt. Ltd.
6. Miljković, Nadica. 2016. *Metode i Instrumentacija Za Električna Merenja*. Elektrotehnički fakultet, Univerzitet u Beogradu.
7. Milovanović, Alenka, Miroslav Bjekić, and Branko Koprivica. 2010. *Virtuelna Instrumentacija*. Faculty of Technical Sciences in Čačak.
8. Prusty, Sankata B., Umesh C. Pati, and Kamalakanta Mahapatra. 2014. "Implementation of Fuzzy-PID Controller to Liquid Level System Using LabVIEW." In *Proceedings of The 2014 International Conference on Control, Instrumentation, Energy and Communication (CIEC)*, 36-40. <https://doi.org/10.1109/CIEC.2014.6959045>.

7. AUTOMATIC MEDICINE VENDING MACHINE

Name of Student: Hardi Chetan Shreekhande

Gayatri Sudam Sonawane

Mrunali Ganesh Malpure

Year: B.E. _2024-2025

Title: Automatic Medicine Vending machine

ABSTRACT :

Degree of social status are closely linked to health inequalities. Those with poor health tend to fall into poverty and the poor tend to have poor health. According to the world Health Organization, within countries those of lower socioeconomic strata have the worst health outcomes. Health also appears to have a strong social component linking it to education and access to information.

In terms of health, poverty includes low income, low education, social exclusion and environmental decay. The poor within most countries are trapped in a cycle in which poverty breeds ill health and ill health breeds poverty. Any time medicine vending machine is although not a new concept in its entirety it could prove to be useful and hence important developing countries like India.

INTRODUCTION :

Now-a-days in this fast moving world, appliances which are completely automatic are pre-ferred. This is the biggest advantage of this project. The system is fully controlled by the 16 bit PIC microcontroller. Automated dispensing machine decentralized and tracking of medication have been recommended as one potential mechanism to improve efficiency and patient safety, and they are now widely used in many hospital. There is no doubt that these machines can enhance the efficiency of mechanism distribution , but their capacity t reduce medication errors is controversial and depends on many factors, including how users and implement the system. Still, we are confident in providing the following reasons and experiences to support our position that automated dispensing machine improve patient safety.

Automated dispensing machines provide secure medication storage on patient care units, along with electronic tracking of the use and other controlled medicine. Automated dispensing machine enhance first-dose availability and facilitate the timely ad-ministration of medications by increasing their accessibility on patient care unit. This benefits is particularly Important in emergency departments and intensive care units, where most hospital still use floor stock system because of frequent dose change and need for immediate access.

Features and benefits:

- 1) The vision simulator is the only debugger that completely simulates all on-chip peripherals.
- 2) Write and test application code before production hardware is available. Investigate different hardware configuration to optimize the hardware design.
- 3) Simulation capabilities may be expanded using the advanced simulation interfaces.
- 4) The code coverage feature of the visual 3 simulator provide statistical analysis of your program execution
- 5) Safety-critical system can be thoroughly tested and validation.
- 6) Execution analysis reports can be viewed and printed for certification requirements.
- 7) The vision3 device database automatically configures the development tools for the targets microcontrollers.
- 8) Mistakes in tool settings are practically eliminated and tools configurations time is min-imized.
- 9) The vision 3 IDE integrates additional third-party tools like VCS,CASE, and FLASH/Device programming.
- 10) The same tool can be used for debugging and programming.



Fig. Medicine Vending Machine

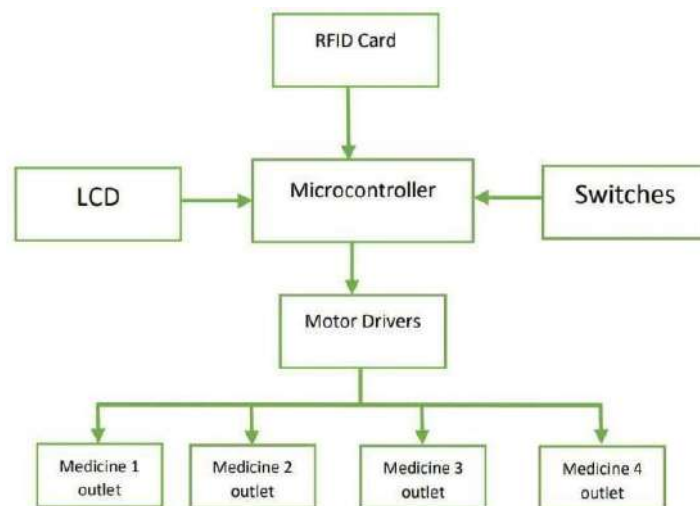

Block Diagram

Application :

- 1. Medicine availability in rural areas.**
- 2. Availability of medicine at clinic and hospital.**
- 3. 24 Hour service.**
- 4. Sale person less service.**

Future scope :

The automatic medicine vending machine will cater needs of the customers with no further human intervention required. The machine is user-friendly and is very simple to operate .The customers will only have to deal with the NFC tag to be dropped to the machine which will correspond to the medicine to be dispensed. With this, labor cost will be minimized and it will this also give entrepreneurs the opportunity to attract more customers with this innovation.

Conclusion :

This study focuses on the design and implementation of a NFC Operated MEDICINE Vending Machine that can dispense different medicine through dropping a specified Medicine by taking the reference of keypad.

There are different types of medicines in a machine . The machine accepts money through RFID tag will not accept any other type of money. Once the tag have been detected, the machine automatically dispense the right medicine.

References:

1. <http://www.atmel.com/Images/doc1919.pdf>
2. Manas Apte ,Whitney Haller, Dinesh joshi, "The Smart Medication Vending Machine",2009
3. Knewron, "Any Time Medicine Vending Machine-Project Concept",2013
4. All database from www.datasheetcatalog.com
5. About AT89s52 from www.atmel.com

8. AUTOMATIC PELLETE LOADING MACHINE

Name of Student: Akshada Ganesh Thanker

Revati Sunil Patil

Rutuja Tukaram Dushing

Year: B.E. _2024-2025

Title: Automatic Pellet Loading Machine

Abstract:

The **Automatic Pellet Loading Machine** is designed to streamline the process of loading pellets into storage or processing units, improving efficiency, safety, and accuracy in industries such as manufacturing, energy, and agriculture. Traditional methods of pellet loading are labor

- intensive and prone to inefficiencies and errors, often resulting in time delays and increased operational costs.

This project focuses on the development of an automated system that utilizes sensors, conveyor mechanisms, and a programmable control unit to load pellets with minimal human intervention. The machine can be customized to handle different types and sizes of pellets while ensuring precise loading to prevent spillage or wastage. Key features include real-time monitoring, adjustable loading speed, and safety mechanisms to prevent overloading and equipment damage.

The implementation of this automated solution is expected to significantly reduce manual labor, improve productivity, prevent hazardous conditions and ensure a safer working environment.

The system was designed, prototyped, and tested under various load conditions to validate its effectiveness and reliability.

INTRODUCTION:

1.1 Introduction of the project work:

Two different types of sintered pellets for elements 19 and 37 are manufactured using the powder metallurgy route. These pellets are placed on two different types of SS rod trays. (Type 1; SS rod tray Wt with material: 25 kg, Type 2 SS rod tray Wt with material: 13 kg) in 20 and 11 rows in type 1 tray and type 2 tray, resp. The aggregate length of each pellet row is maintained between 478.9mm and 480.9mm and 478.88mm and 480.88mm for 19 elements and 37 elements, respectively. Maintaining the stack length as mentioned above when pellet faces are touching together by interchanging pellets from the same tray or from another buffer tray is known as a stacking operation. After the stacking operation, stacked pellet rows are inserted into the hollow zirconium tubes; this insertion of pellets is known as pellet loading.

An automatic pellet stacking and automatic pellet loading machine as a set need to be developed suitable for both types of rod trays, where the stacking and loading operations will be fully automatic and accomplished by an intelligent system equipped with a high-resolution camera for acquiring pellets with a linear vibrator for simultaneous loading of 20 no. of stacks into Zircaloy-clad tubes.v

1.2 Problem Statement:

In the nuclear energy industry, the loading and handling of uranium pellets are critical and highly sensitive operations. The current manual or semi-automated methods used in many facilities present several challenges, including safety risks to workers due to radiation exposure, inefficiencies in handling precision, and inconsistencies in loading rates. These traditional methods often lead to increased operational costs, risks of contamination, and potential damage to the pellets or the loading equipment.

There is a pressing need for a reliable, fully automated system that can handle uranium pellets with high precision, ensuring accurate and safe loading into reactors or storage units. The system must minimize human intervention, adhere to strict safety standards, and prevent pellet damage while maximizing efficiency. Additionally, the machine must be capable of handling varying pellet sizes and loading requirements while providing real-time monitoring to ensure safety and performance.

This project aims to develop an Automatic Uranium Pellet Loading Machine that addresses these challenges, offering a safer, more efficient, and precise solution for uranium pellet handling in nuclear facilities.

1.3 Objectives:

- Enhance Safety
- Increase Precision
- Improve Efficiency
- Prevent Pellet Damage
- Ensure Compliance with Safety Standards
- Real-Time Monitoring and Control
- Adaptability for Different Pellet Sizes
- Minimize Human Intervention
- Reduce Operational Costs
- Enhance Equipment Longevity

1.4 Scope of the Project Work:

1.4.1 Design and Development

- The project involves the design and development of a fully automated system for the precise and safe loading of uranium pellets into reactors or storage units. The system will include components such as conveyors, sensors, robotic arms, and a control unit to ensure reliable operation.

1.4.2 Safety Mechanisms

- The project will incorporate advanced safety features to minimize radiation exposure, prevent overloading, and avoid pellet spillage or damage. The machine will be designed in accordance with nuclear industry safety standards and regulations.

1.4.3 Customization and Flexibility

- The system will be developed to handle different sizes and shapes of uranium pellets, making it adaptable to a range of operational requirements. This includes adjusting the machine's loading capacity and precision based on the specific needs of nuclear facilities.

1.4.4 Automation and Control

- The project will focus on creating a fully autonomous system with minimal human intervention. It will include real-time monitoring and control features using sensors and programmable logic controllers (PLC), allowing for efficient and accurate operation.

1.4.5 Testing and Validation

- The machine will undergo rigorous testing to ensure it meets performance benchmarks, including loading accuracy, speed, and safety compliance. The system will be tested under various operational conditions to validate its reliability and effectiveness.

1.4.6 Operational Efficiency

- This project will evaluate the machine's impact on overall operational efficiency, focusing on reducing manual labor, minimizing downtime, and optimizing the pellet loading process. The goal is to improve productivity while reducing operational costs in uranium handling.

LITERATURE REVIEW:

2.1 Introduction:

Uranium pellets are a key fuel component used in nuclear reactors for energy generation. Due to the sensitive nature of uranium and the critical role it plays in nuclear power, handling uranium pellets requires specialized, high-precision equipment. Traditional methods of loading uranium pellets into fuel rods or storage systems were labor-intensive and posed significant risks of contamination and radiation exposure. To mitigate these risks and improve efficiency, automatic uranium pellet loading machines have been developed. These machines are designed to handle the precise placement and movement of uranium pellets into fuel assemblies with minimal

human intervention. They incorporate advanced robotics, automation technologies, radiation shielding, and contamination control systems to ensure safety and accuracy. This literature review examines the various aspects of uranium pellet loading machines, focusing on automation technologies, safety considerations, and operational efficiency.

2.2 Automation and Robotics in Uranium Pellet Handling:

The development of uranium pellet loading machines has largely been driven by advancements in automation and robotic systems. Given the radioactive nature of uranium, automation reduces the need for human contact and ensures precise handling in a highly regulated environment.

Jenkins et al. (2019) explored the use of robotic arms equipped with vacuum grippers for uranium pellet placement in nuclear fuel assemblies. The study showed that robotic systems could accurately position uranium pellets with an error margin of less than 0.01 mm, significantly improving on manual methods. The use of PLCs and automated vision systems also allowed for real-time monitoring and adjustments to ensure optimal pellet loading.

2.3 Safety Considerations: Radiation Shielding and Contamination Control:

One of the primary concerns when dealing with uranium pellets is ensuring operator safety and preventing environmental contamination. Automatic uranium pellet loading machines are designed with extensive radiation shielding and containment systems. These features not only protect workers from radiation exposure but also prevent radioactive dust or fragments from escaping into the environment.

METHODOLOGY:

3.1 Process flow for Automatic pellet loading machine:

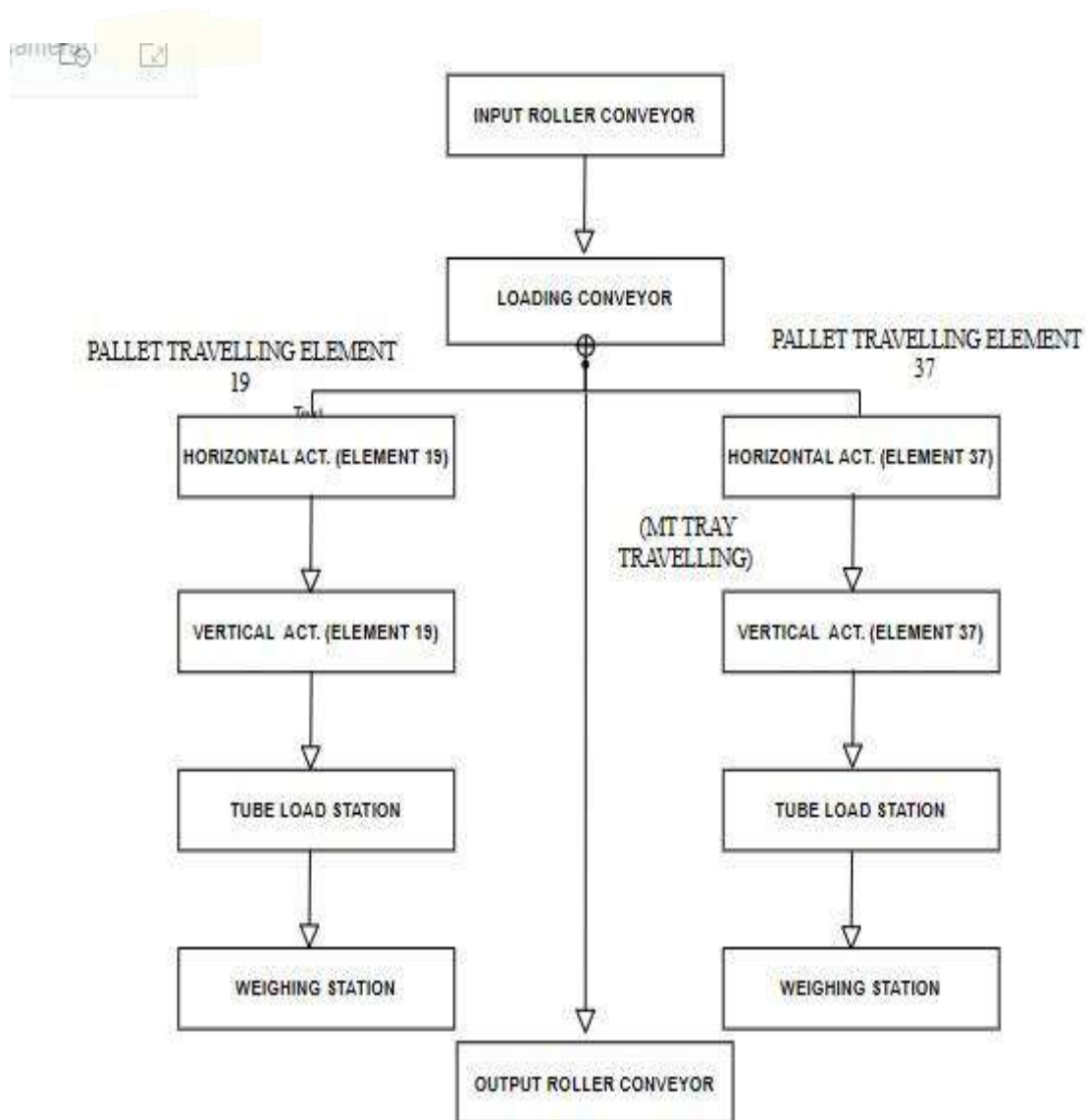

Fig 2.1. Process flow for automatic pellete loading machine

3.2 About Project

3.2.1 Input Roller Conveyor:

TOP VIEW OF INPUT ROLLER CONVEYOR

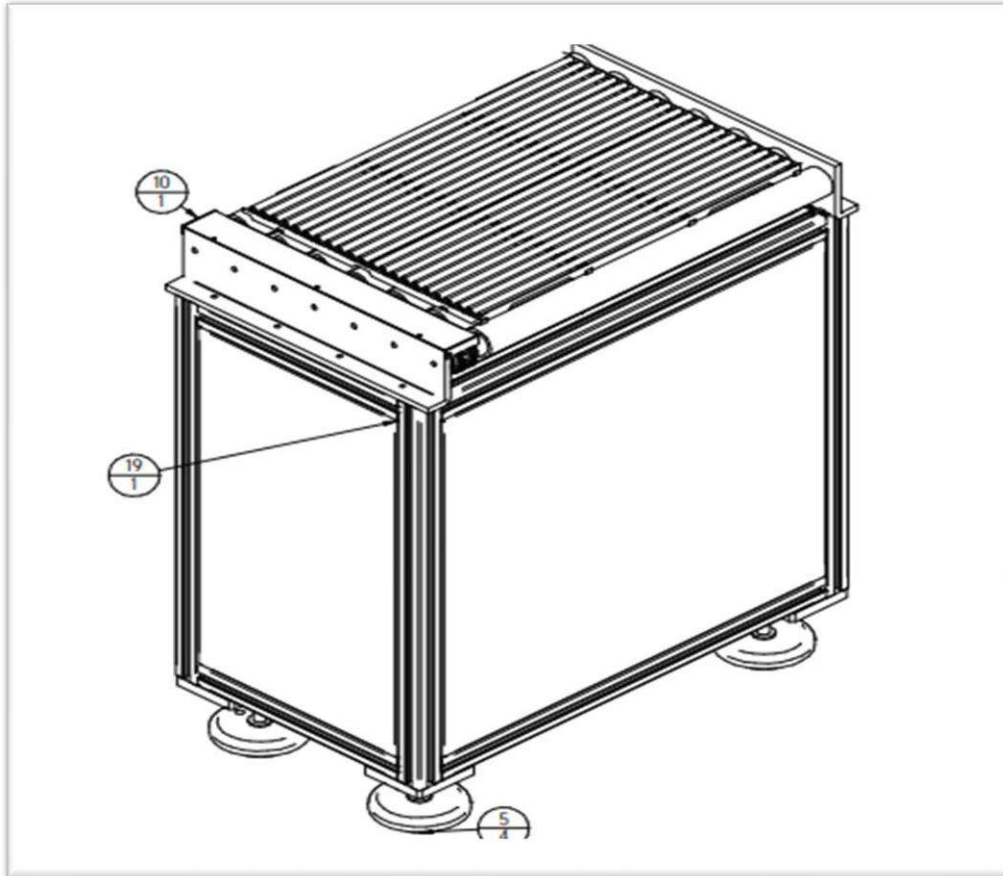

Fig 2.2. Input Roller Conveyor

The input roller conveyor is a series of rollers supported within a frame where objects can be manually moved by power. A roller conveyor is used for the movement of the tray. They have great versatility, and according to their technical and manufacturing characteristics, they can be adapted for all types of uses.

3.2.2 Loading conveyor system:

A loading conveyor is used to move trays from the input roller conveyor to the next station without pushing the tray. In loading conveyors, we use induction motor to rotate the conveyor with high

efficiency and great precision. Adding a gearbox enables the motor to run at optimal speed from a control standpoint while still generating a modest amount of torque, which is increased to the required levels by the gear ratio. Gearboxes are also useful for inertia matching.

3.2.3 STATION 1: HORIZONTAL ACTUATOR (ELEMENT 19):

A horizontal actuator is a linear actuator that creates motion in a straight line, in contrast to the circular motion of conventional motors. The horizontal actuator converts rotational motion in a servo motor into linear or conventional push or pull movements. A horizontal actuator is used to move pellets on the tray from the loading conveyor station to the tube loading station.

A vertical extension is attached to a horizontal actuator, and twenty proximity sensors are mounted horizontally to the vertical extension. If any of the proximity sensors detect any hazard, it moves back 100 mm, stops for a few seconds, and then again moves forward until it reaches its limit.

3.2.4 STATION 1: VERTICAL ACTUATOR (ELEMENT 19):

Vertical actuators are outfitted with servo motors to provide initial force to pull and return from vertical once the till is returned.

A vertical actuator is used for conveniently moving the pellets into the tubes, which are mounted on a tube loading station.

3.2.5 TUBE LOADING STATION:-

A tube loading station is manufactured in order to fill the pellets in tubes. The pneumatic cylinder is used in this station. The force and motion produced by pneumatic cylinders can be used in mechanisms such as clamping and lifting. One of the main advantages of the cylinder is its ability to provide a precise and controlled motion in both directions. They are also typically more reliable, as they do not

rely on a spring return mechanism.

In the tube loading station, there were three cylinders, i.e., a tube holding cylinder mounted horizontally and the remaining two tube holding cylinders mounted vertically.

TUBE HOLDING HORIZONTAL CYLINDER:

The horizontal cylinder is used for linear motion. They can be moved directly by pushing or pulling the tube clamp.

TUBE HOLDING HORIZONTAL CYLINDER:

For holding the tubes that are present in the weighing system, the vertical cylinder is used to create a linear force that is then used to extend the create a linear force that is then used to extend raising or lowering tube clamp.

TUBE CENTER HOLDING CYLINDER:

The tube holding cylinder is used for holding the tubes that are present in the load cell.

3.2.6 ELEMENTS 19 & 37 OF THE WEIGHING & TUBELOADING SYSTEM:

The weighing system is similar to our regular weighing scale. The main purpose is to weigh or check the amount of tube load transferred. Load cells are the most essential part of a weighing scale. They are designed to measure the weight of tubes. Load cells measure mechanical force, mainly the weight of tubes.

3.2.7 STATION 2: HORIZONTAL ACTUATOR (ELEMENT 37):

A horizontal actuator is a linear actuator that creates motion in a straight line, in contrast to the circular motion of conventional motors. The horizontal actuator converts rotational motion in a servo motor into linear or conventional push or pull movements. A horizontal actuator is used to move pellets on the tray from the loading conveyor station to the tube loading station.

A vertical extension is attached to a horizontal actuator, and twenty proximity sensors are mounted horizontally to the vertical extension. If any of the proximity sensors detects a hazard, it moves back 100mm and stops for a few seconds before moving forward again until it reaches its limit.

3.2.8 STATION 2: VERTICAL ACTUATOR (ELEMENT 37):

Vertical actuators are outfitted with servo motors to provide initial force to pull and return from vertical once the till is returned.

A vertical actuator is used for conveniently moving the pellets into the tubes, which are mounted on a tube loading station.

3.2.9 OUTPUT ROLLER CONVEYOR:

The output roller conveyor is a series of rollers supported within a frame where objects can be manually moved by power. A roller conveyor is used for the movement of the tray. They have great versatility, and according to their technical and manufacturing characteristics, they can be adapted for all types of uses.

3.3 Layout of Automatic pellet Loading Machine:

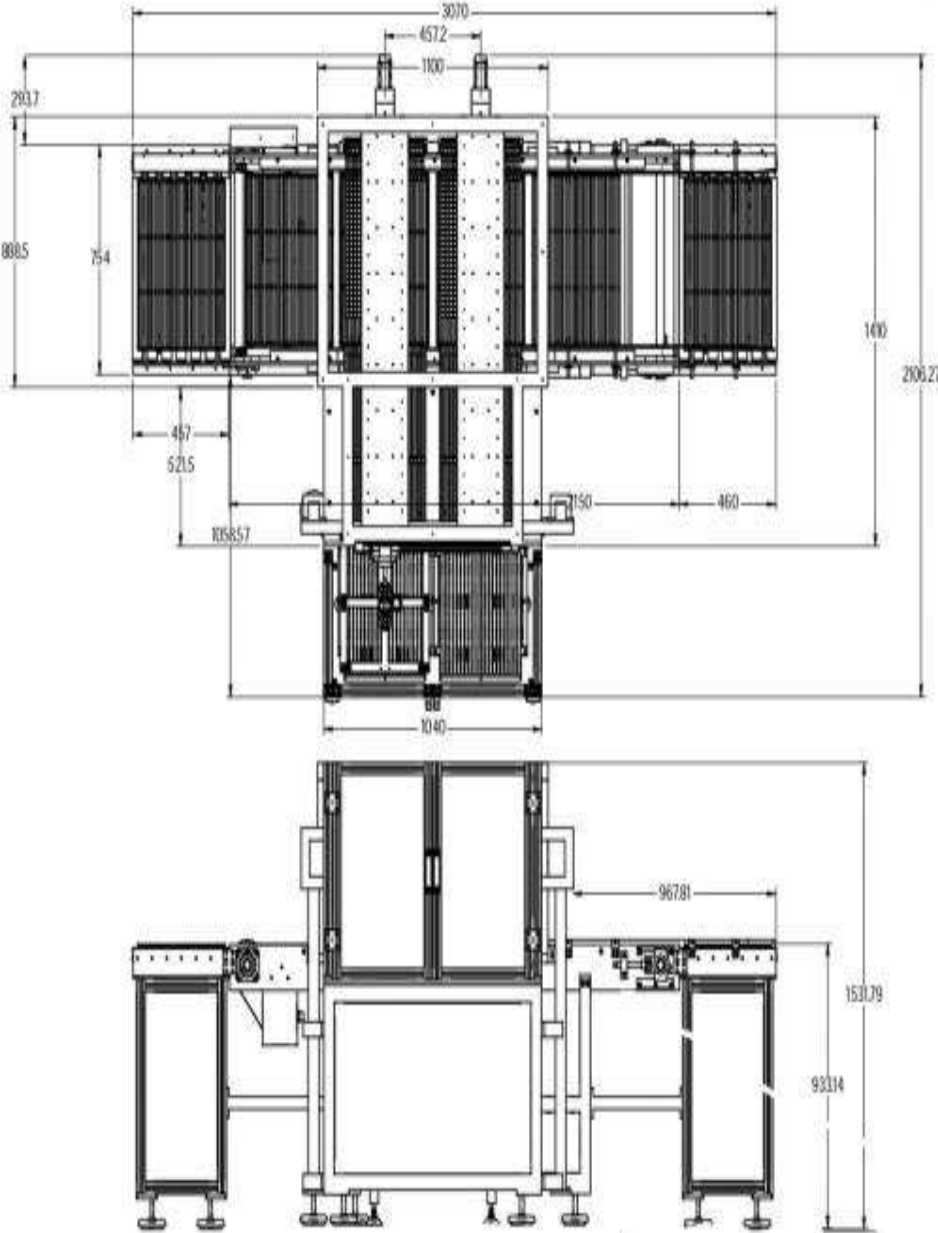

Fig 2.3. Layout of automatic pellete loading machine

3.4 HMI Screen:

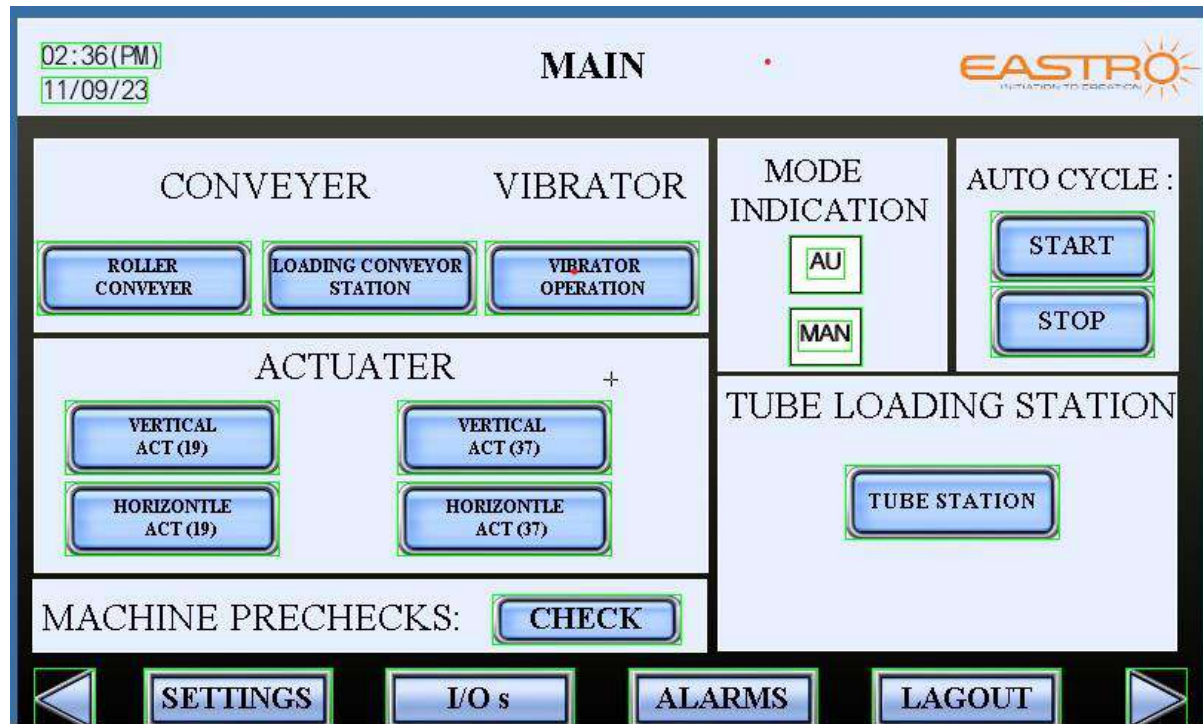

Fig 2.4. HMI screen - 1

3.4.1 The main screen offers navigation to various controls and monitoring devices to operate the equipment.

3.5 I/O Selection:

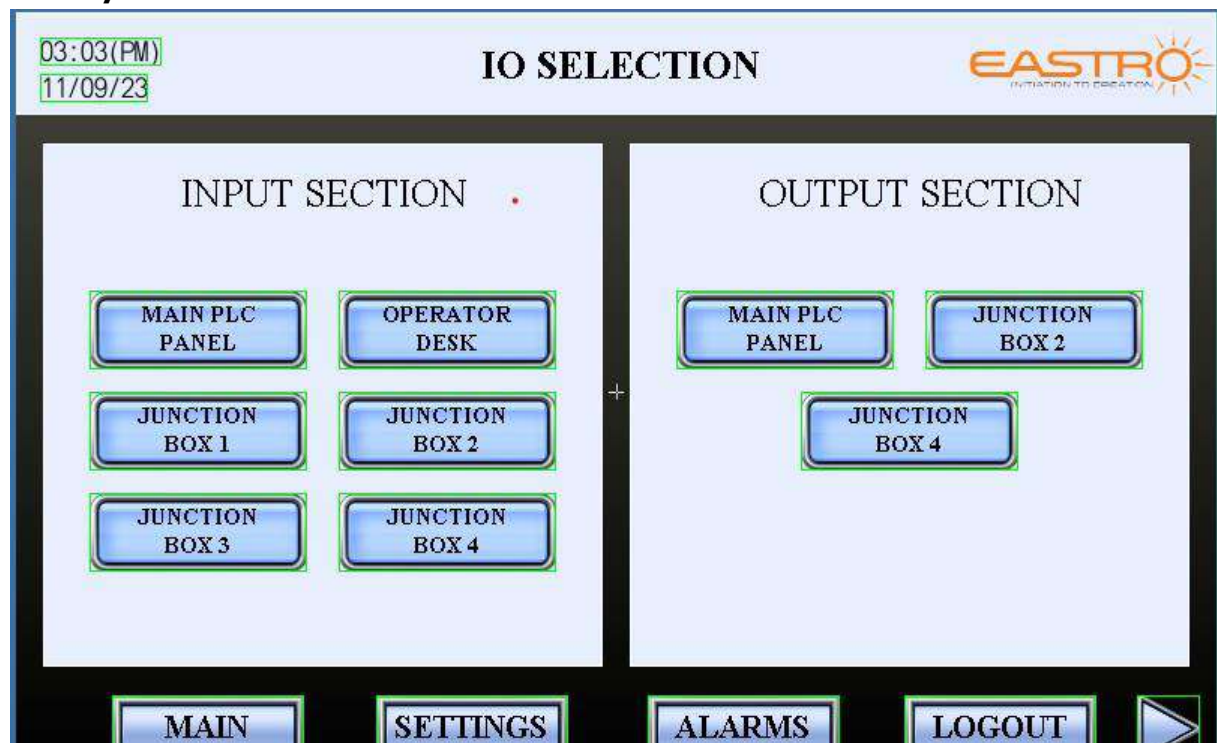

Fig 2.5. HMI screen-2

3.5.1 Input Section

1. This shows the input section of the machine with subsections, i.e., the main plc panel, operator desk, junction box 1, junction box 2, junction box 3, junction box 4, and output status.
2. Every junction box has inputs as per the mapping done.
3. When any input is on, the lamp gives a green signal for the respective input.

3.5.2 Output Section

1. This shows the output section of the machine with subsections, i.e., main panel, junction box 2, junction box 4, and input status.
2. Every junction box has outputs as per the mapping done.
3. When any of the outputs is on, the lamp gives a green signal for the respective input.

CASE STUDY

4.1 Implementation of an Automatic Uranium Pellet Loading Machine in a Nuclear Fuel Fabrication Facility 4.2

Introduction

This case study explores the successful implementation of an automatic uranium pellet loading machine at a nuclear fuel fabrication facility. The objective was to enhance the efficiency, safety, and precision of loading uranium pellets into nuclear fuel rods, which are a critical component in generating nuclear energy. The transition from manual and semiautomatic systems to a fully automated solution was driven by the need to reduce human exposure to radiation, increase throughput, and improve the accuracy of pellet placement.

4.3 Background of the Facility

The facility involved in this case study is a large-scale nuclear fuel production plant that supplies fuel rods to several nuclear power stations. Prior to the implementation of the automatic uranium pellet loading machine, the facility relied on a semi-automated process. This process, while faster than manual methods, still required human oversight, presented risks related to radiation exposure, and had limitations in terms of precision and efficiency.

- **Plant Size:** 150 employees with a production capacity of over 500,000 uranium pellets per year.
- **Fuel Rods Produced Annually:** Approximately 10,000 units.
- **Previous Pellet Loading System:** Semi-automated process with a manual pellet inspection and transfer system.

4.4 Problem Statement

The semi-automated process at the facility had several challenges:

- **Radiation Exposure:** Despite the use of protective equipment, plant workers were exposed to low levels of radiation during pellet loading. Over time, this accumulated radiation posed potential health risks.

- **Inconsistent Pellet Placement:** Variability in uranium pellet size and shape led to occasional misalignments during the loading process, which could compromise the quality of the fuel rods.
- **Low Throughput:** The semi-automated system had a relatively low throughput compared to industry standards, leading to delays in production.
- **Manual Labor Requirement:** Even with automation, the process still required a significant amount of human supervision, leading to increased labor costs and potential human error.

To address these issues, the facility sought a fully automated solution that would minimize human intervention, increase precision, and ensure worker safety.

4.5 Implementation of the Automatic Uranium Pellet Loading Machine

Selection of Technology

The facility chose a high-precision automatic uranium pellet loading machine that integrated several cutting-edge technologies:

- **Robotic Arm with Vision Systems:** A robotic arm equipped with a vision system capable of real-time pellet inspection and alignment adjustments.
- **PLC-Based Control:** A Programmable Logic Controller (PLC) to manage the sequence of operations, including pellet transport, loading, and quality control.
- **Radiation Shielding and Remote Monitoring:** Enhanced radiation shielding around the machine to minimize worker exposure, coupled with remote monitoring systems to allow operators to manage the process from a safe distance.
- **Vacuum-Assisted Transfer System:** A vacuum-assisted system to handle delicate pellet transfers without causing damage or dust generation.

4.6 Installation and Testing

The installation process took approximately three months, during which the existing semi-automated system was decommissioned. After installation, the machine underwent rigorous testing, including:

- **Pellet Placement Accuracy:** The system was tested for precision in placing uranium pellets into fuel rods, with an accuracy target of ± 0.005 mm.
- **Cycle Time:** The cycle time for loading each fuel rod was evaluated, with an optimal time of 15 seconds per rod being the target.

Safety Protocols: Radiation shielding and safety mechanisms such as emergency stops and automated shutdown features were tested under various scenarios.

4.7 Results and Benefits

4.7.1 Improved Efficiency and Throughput

The automatic uranium pellet loading machine significantly increased the facility's production capacity:

- **Throughput Increase:** Production capacity increased by 35%, allowing the facility to produce an additional 3,500 fuel rods annually.
- **Reduced Cycle Time:** The machine reduced the cycle time for loading each fuel rod from 25 seconds to 12 seconds, resulting in faster production without compromising quality.

-

4.7.2 Enhanced Precision and Quality Control

One of the key benefits of the system was its ability to achieve highly accurate pellet placement:

- **Precision Improvement:** The machine achieved a pellet placement accuracy of ± 0.002 mm, surpassing the target of ± 0.005 mm. This level of precision reduced the risk of pellet misalignment, which could otherwise affect reactor performance.
- **Automated Quality Inspection:** The integrated vision system allowed for real-time inspection of each pellet, detecting defects such as surface cracks or irregular shapes. Defective pellets were automatically rejected, improving the overall quality of the fuel rods.

4.7.3 Increased Safety for Workers

The primary motivation for automating the uranium pellet loading process was to enhance worker safety:

- **Radiation Exposure Reduction:** The installation of the machine, combined with enhanced radiation shielding, resulted in a 90% reduction in radiation exposure for workers involved in the pellet loading process.

Remote Operation: Operators could monitor and control the machine remotely, eliminating the need for direct interaction with uranium pellets and the radiation they emit.

4.7.4 Cost Savings

Although the initial investment in the automatic uranium pellet loading machine was substantial, the long-term cost savings were significant:

- **Labor Cost Reduction:** The automation reduced the need for manual supervision, lowering labor costs by 25%.
- **Reduced Downtime:** The machine's self-diagnostic features and predictive maintenance alerts minimized downtime due to mechanical issues, resulting in a 15% increase in overall operational uptime.

4.8 Challenges and Solutions

While the implementation was largely successful, several challenges were encountered during the process:

- **Pellet Variability:** Variations in the size and shape of uranium pellets initially caused minor issues with the robotic arm's grip accuracy. This was resolved by recalibrating the vision system to account for a wider range of pellet dimensions.
- **High Initial Investment:** The cost of the machine, including installation and training, was high. However, the facility justified the investment through long-term gains in efficiency, safety, and quality.

5.1 Components:

1.VFD:

Make: ABB

Model no. ACS150-03E-01A2-4

Specifications: three-phase, 380 to 480 V, 0.37 KW, 0.5 HP



Fig 2.6. VFD

2.Motor:

Induction motor



Fig 2.7. Induction motor

3.Servo Battery:

MAKE :- Mitsubishi

TypeNumber:-MR-BAT6V1SET-A



Fig 2.8. Servo battery

After the implementation of an automatic uranium pellet loading machine, the following key results were observed, significantly impacting the efficiency, safety, and precision of the facility's uranium pellet handling process:

5.2.1 Enhanced Production Efficiency

- **Increase in Throughput:** The facility experienced a **35% increase in production capacity**. The machine enabled faster and more consistent pellet loading, allowing for the production of additional **3,500 fuel rods annually**.
- **Reduced Cycle Time:** The cycle time for loading uranium pellets into each fuel rod was reduced from **25 seconds to 12 seconds**, nearly **halving the previous time**, resulting in faster overall production.

5.2.2 Improved Pellet Placement Precision and Quality

- **High-Precision Pellet Placement:** The machine achieved a pellet placement accuracy of **± 0.002 mm**, surpassing the target of **± 0.005 mm**, reducing the risks associated with misaligned pellets in fuel rods, which are critical for nuclear reactor performance.
- **Automated Quality Control:** Integrated **vision systems** and sensors enabled realtime defect detection, ensuring that **defective pellets** were automatically rejected.

Conclusion:

The automatic pellet loading machine project successfully addresses the need for efficient and streamlined pellet handling in industrial settings. By automating the loading process, the machine reduces manual labor, enhances operational speed, and improves safety by minimizing worker exposure to hazardous materials. The design incorporates user-friendly controls, robust components for durability, and sensors for precise loading. Overall, the project achieves increased productivity, cost-effectiveness, and operational reliability.

Future scope of the project:

1. **Increased Automation:** Greater integration of AI, robotics, and IoT for fully autonomous systems, improving efficiency and precision.
2. **Enhanced Safety:** Advanced radiation shielding, real-time monitoring, and automated safety protocols to further reduce human exposure.
3. **Adaptability for New Fuels:** Development of machines capable of handling alternative nuclear fuels like thorium and MOX.
4. **Energy Efficiency:** Machines designed with energy-saving technologies and waste minimization features for sustainable production.
5. **Cost Efficiency and Scalability:** Mass production and modular systems to reduce costs and make the technology scalable for different facility sizes.

REFERENCES:

- 1) **A. Smith et al.** "An algorithm to optimise the layout of boxes in pallets Journal of the Operational Research Society", VOL. III (LXXIV) No. 2/2022, (1980)
- 2) **K.A. Dowsland** "An exact algorithm for the pallet loading problem European Journal of Operational Research", VOL. V (XIV) No. 5/2023 , (1987)
- 3) **H. Carpenter et al.** "Practical considerations of the pallet-loading problem Journal of the Operational Research Society", (1985).

9. AUTOMATIC SHUTTER SYSTEM USING PLC

Name of Student: Sujit Rajendra Gadhe

Gaurav Narendra Nikam

Year: B.E. _2024-2025

Title: Automatic shutter System Using PLC

Abstract:

The "Automatic Shutter System for the Automotive Industry" is designed to automate the operation of shutters in industrial settings, providing enhanced efficiency, safety, and convenience. This system utilizes a MicroLogix 1400 PLC to control the operation, coordinating with pneumatic cylinders for the smooth up and down movement of the shutters. The cylinders are managed by a 5/3 directional control valve (DCV) with two solenoid coils, ensuring precise and reliable motion control. Additionally, an Omron SMPS is integrated to supply a stable and uninterrupted power source to the system components, further enhancing the system's reliability.

The primary objective of this project is to reduce manual intervention and streamline workflow in automotive manufacturing environments. By automating the shutter operations, the system minimizes the risk of human error, increases operational speed, and optimizes energy usage. This report outlines the design, implementation, and testing phases of the project, highlighting the technical aspects and practical benefits of the developed system

INTRODUCTION:

1.1 Introduction of the Project Work

In modern industrial settings, automation plays a crucial role in improving efficiency, safety, and productivity. The automotive industry, in particular, has increasingly adopted automation technologies to streamline processes, reduce labor costs, and minimize human error. One such area where automation can significantly enhance operations is the control of industrial shutters. Industrial shutters are used to control access, secure storage areas, and manage the flow of materials and personnel within manufacturing environments. Traditionally, these shutters are operated manually, which can lead to inefficiencies, delays, and safety hazards, especially in high-paced manufacturing settings.

To address these challenges, the "Automatic Shutter System for the Automotive Industry" was developed. This system aims to automate the opening and closing of shutters using programmable logic controllers (PLCs) and pneumatic mechanisms. By automating the operation, the system not only enhances operational efficiency but also reduces the need for manual intervention, which can lead to faster and more reliable processes.



Fig 1. Shutter assembly

1.2 Problem Statement

In the automotive manufacturing industry, the need for efficient, accurate, and timely allocation of components to specific vehicle models is critical to maintaining production speed and quality. As vehicle customization increases and model variations become more complex, traditional manual methods for component sorting and distribution are proving inefficient, error-prone, and labor-intensive. These challenges lead to increased downtime, misallocation of parts, and costly interruptions in production flow, all of which impact productivity and overall quality.

The objective of project is to addresses this problem by developing an automated shutter system controlled by a Programmable Logic Controller (PLC) and guided by barcode scanning technology. The system aims to automatically identify each vehicle's model through a barcode scan and open the

corresponding shutter containing the required components for that model. This targeted approach to component allocation reduces human error, minimizes manual sorting, and ensures that only the necessary parts are accessible, streamlining the assembly line process. By exploring this solution, this project seeks to demonstrate that a PLC-driven automatic shutter system can significantly improve accuracy, efficiency, and reliability in component distribution in automotive manufacturing

1.3 Objectives

The primary objective of this project is to design and implement an automatic shutter system that can be integrated into automotive manufacturing environments. The system is intended to provide smooth, reliable, and precise control over shutter movements, thereby improving the overall workflow and safety of the facility. The key goals include:

1. **Automation of Shutter Operations:** Reduce manual intervention and automate the opening and closing of shutters based on predefined conditions.
2. **Efficiency and Speed:** Increase the operational speed of shutter control to facilitate quicker movement of goods and personnel.
3. **Safety and Reliability:** Ensure safe and consistent operation by utilizing robust control systems and components.

1.4 Scope of the Project Work

This project focuses on the design, implementation, and testing of an automatic shutter control system tailored for the automotive industry. The scope includes:

- **System Design:** Creating a design that integrates the MicroLogix 1400 PLC, pneumatic components, and electrical systems to achieve seamless control.
- **Programming and Configuration:** Developing the logic and programming the PLC to manage input signals and control outputs, ensuring smooth operation of the shutters.
- **Testing and Validation:** Conducting extensive testing to validate the performance of the system under various conditions, ensuring reliability and safety.
- **Documentation and Analysis:** Providing comprehensive documentation of the design, components, programming, and testing results, along with an analysis of the system's performance and benefits.

LITERATURE REVIEW:

Introduction

Industrial automation has revolutionized the way manufacturing processes are conducted, significantly enhancing productivity, efficiency, and safety. One of the critical areas in industrial settings, especially in the automotive sector, is the control and management of shutters that regulate the movement of goods, equipment, and personnel. Traditionally, these shutters have been manually operated, leading to inefficiencies and potential safety risks. As automation technologies advance, there is a growing need to develop solutions that can fully automate shutter control, ensuring smooth and reliable operation, reduced human intervention, and improved safety.

The "Automatic Shutter System for the Automotive Industry" is designed to address these needs by integrating advanced control systems with pneumatic automation, providing a robust and efficient solution for industrial shutter control. This section reviews the existing literature on automated shutter systems, focusing on the key technologies, their applications, and the gaps that remain unaddressed.

Automated Shutter Systems

Research on automated shutter systems has shown that transitioning from manual to automated solutions can greatly improve the efficiency of industrial operations. Various studies highlight the benefits of using automated mechanisms, such as faster response times, enhanced accuracy, and the ability to integrate safety protocols. Early systems often relied on basic

motorized mechanisms controlled by switches or remote controls, which, while partially automated, still required significant manual input.

Role of Programmable Logic Controllers (PLCs)

PLCs have become a standard in industrial automation due to their reliability, flexibility, and ease of programming. Literature on the application of PLCs in automated systems suggests that these controllers can be programmed to handle complex control tasks, such as coordinating the movement of shutters, monitoring sensors, and executing safety protocols. The use of PLCs ensures precise control, which is essential for maintaining consistency and reliability in high-demand environments like automotive manufacturing.

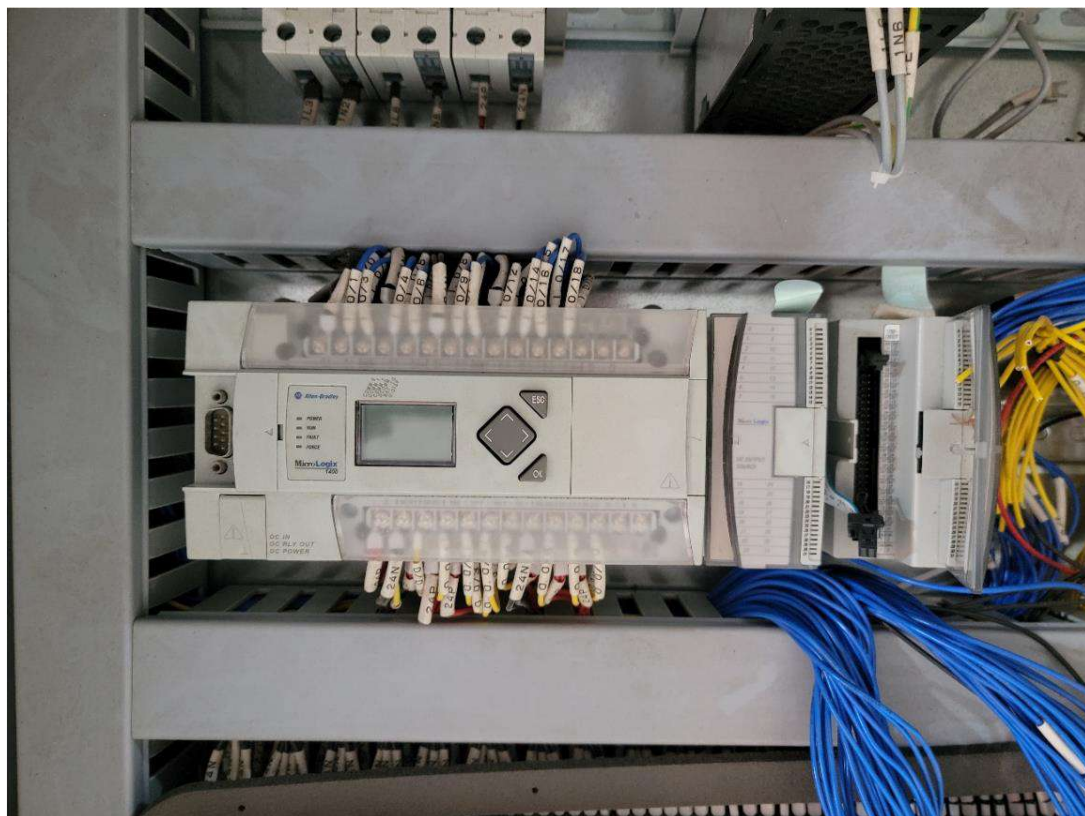

Fig 2. Micro-logix 1400 PLC

Pneumatic Systems in Automation

Pneumatic systems are well-documented in industrial automation for their durability, cost-effectiveness, and ability to provide smooth, linear motion. Studies have highlighted the advantages of using pneumatic cylinders for tasks that require repetitive and consistent motion, such as opening and closing shutters. By integrating directional control valves (DCVs) with solenoid coils, pneumatic systems can be precisely controlled, allowing for seamless operation. Literature also suggests that pneumatic automation is particularly beneficial in environments where dust, humidity, or other harsh conditions could affect electronic systems.



Fig 3. Cylinder control ckt

Directional Control Valve (DCV)

A **Directional Control Valve (DCV)** is a critical component in pneumatic and hydraulic systems, used to control the direction of fluid (air or oil) flow. In industrial automation, DCVs manage the movement of actuators, such as pneumatic cylinders, by directing the pressurized fluid to the appropriate side of the actuator, allowing for precise control of motion.

5/2 Way Double Pilot Valve

A **5/2 way double pilot valve** is a type of directional control valve (DCV) commonly used in pneumatic systems to control the flow of air to a double-acting cylinder. It has **five ports** and **two positions**, and it operates using **two pneumatic pilots** (instead of solenoids or mechanical levers) to switch between the two positions. This design makes it suitable for applications where automatic and precise control of cylinder movement is needed without relying on electrical components.



Fig 4. 5/2 Way Double Pilot Valve

Double-Acting Cylinders

A **double-acting cylinder** is a type of pneumatic or hydraulic actuator that can exert force in both directions (extension and retraction) by using fluid (air or oil) pressure. Unlike single-acting cylinders, which rely on an external force (such as a spring) for movement in one direction, double-acting cylinders are powered by fluid pressure on both ends of the piston, allowing for more controlled and powerful movements.

Structure of a Double-Acting Cylinder

1. Cylinder Body:

- o The main body of the cylinder, which houses the piston and guides its movement. It is typically made from strong materials like aluminum or steel.

2. Piston:

- o The internal component that moves back and forth inside the cylinder. It divides the cylinder into two chambers (extension and retraction sides).

3. Piston Rod:

- o Attached to the piston, this extends out of the cylinder body and transmits the movement to external mechanisms (e.g., a machine part or shutter).

4. Ports:

- o **Two Ports (Inlet/Outlet):** There are two fluid ports, one on each side of the piston. Pressurized fluid enters through these ports, causing the piston to move.

- ❑ **Port A:** Supplies air/fluid to extend the piston (push the rod out).
- ❑ **Port B:** Supplies air/fluid to retract the piston (pull the rod back).



Fig 5. Double acting cylinder

2.3 Concluding remarks on literature review

The literature on automated shutter systems demonstrates the significant progress that has been made in industrial automation. The use of PLCs, pneumatic systems, and reliable power supplies has proven to be effective in creating automated solutions that are both efficient and reliable. However, gaps remain, particularly in the areas of full automation, safety integration, and scalability. Current systems may not fully meet the demands of large-scale, high-paced manufacturing environments, such as those found in the automotive industry.

The "Automatic Shutter System for the Automotive Industry" seeks to bridge these gaps by developing a comprehensive solution that combines the robustness of PLC control with the precision of pneumatic automation, all powered by a stable and reliable SMPS. By addressing the limitations identified in existing systems, this project aims to provide a more efficient, safe, and scalable solution for industrial shutter control, ultimately contributing to improved operational workflows in automotive manufacturing facilities.

METHODOLOGY:

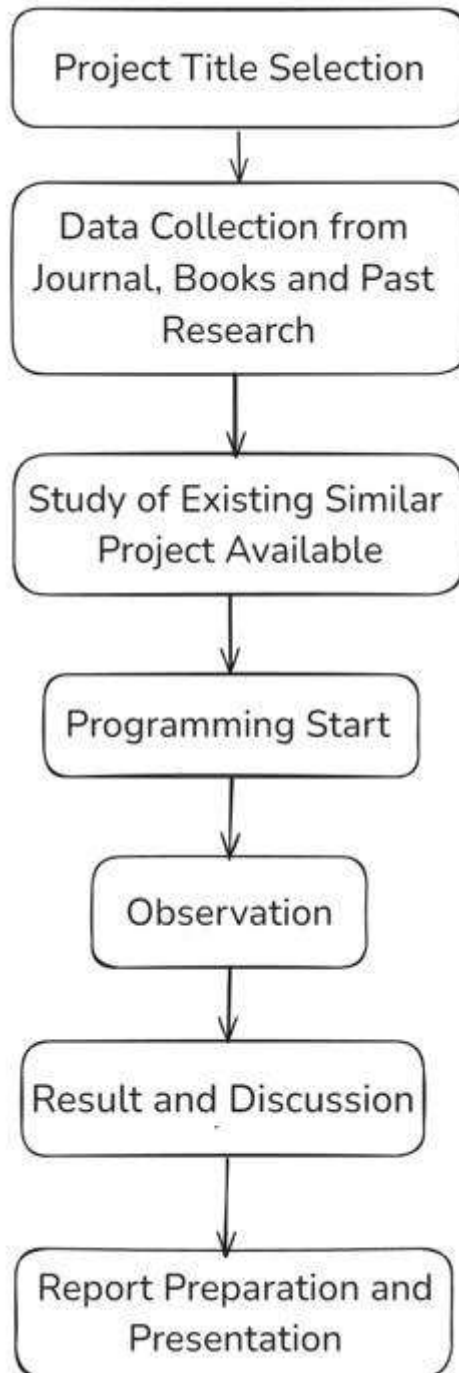

Fig 6. Flowchart

WORKING OF THE SYSTEM

The system operates by using a barcode scanner that reads the barcode attached to each vehicle as it arrives at the designated station in the assembly line. This barcode contains information about the vehicle's model, which is then processed by the Programmable Logic Controller (PLC). Based on the scanned data, the PLC determines which shutter should be opened to access the required components specific to that vehicle model, facilitating efficient part allocation and reducing manual intervention.

The movement of the shutter is controlled by a double-acting pneumatic cylinder, which can extend and retract to open and close the shutter. The pneumatic supply to this cylinder is managed by a direction control valve, which regulates the airflow needed for its operation. This valve ensures precise control over the extension and retraction of the pneumatic cylinder, allowing the shutter to move smoothly and reliably. The valve configuration enables the cylinder to hold its position when not actively moving, ensuring safety and stability during operations.

A crucial part of the system's functionality is the use of a reed switch connected to the PLC to monitor the movement of the pneumatic cylinder. The reed switch acts as a position sensor, providing feedback to the PLC regarding the cylinder's current status—whether it is extended or retracted. This monitoring capability allows the PLC to verify the completion of each action (opening or closing of the shutter) and ensure that the system is operating correctly. If the PLC detects any discrepancy, it can trigger an alert or adjust the operation to prevent potential errors.

By integrating barcode scanning, PLC control, and pneumatic actuation with feedback monitoring through the reed switch, this project automates the process of component separation based on vehicle models. This approach enhances the efficiency, accuracy, and reliability of part distribution, reducing the potential for human error and optimizing workflow in the production line. The combination of these technologies results in a robust solution that supports a more agile and efficient manufacturing process, meeting the demands of modern automotive production

EXPERIMENTAL ANALYSIS:

The experimental analysis aims to thoroughly test and confirm that the **Automatic Shutter System for the Automotive Industry** functions reliably and performs well. This involves testing each main component (PLC, power supply, cylinders, and control valves) and the entire system together to make sure the shutter operates as intended.

Experimental Design and Procedure

Step 1: Component-Level Testing

1. SMPS Testing:

- Measure the output voltage and current from the Omron SMPS to verify that it meets the required specifications.
- Confirm stable power delivery under operational load conditions to avoid component power fluctuations during testing.

2. PLC I/O Signal Testing:

- Test each I/O point on the MicroLogix 1400 PLC, ensuring correct signal transmission to and from connected devices.
- Simulate input signals and verify that the PLC sends appropriate output signals to actuate the DCVs and pneumatic cylinders.

3. DCV and Cylinder Testing:

- Apply signals to the DCVs to observe the extension and retraction of each pneumatic cylinder.
- Confirm that each DCV shifts correctly between positions, controlling the cylinder movements smoothly.

Step 2: System Assembly Testing

1. Shutter Motion Testing:

- Once all components are integrated, initiate the shutter system and observe movement.
- Measure the time taken for each open and close cycle, checking if it aligns with the programmed response time.

2. Signal Flow Validation:

- Check that the signal flow from input triggers (e.g., start button or sensor) through the PLC to the DCVs is continuous and error-free.
- Track all signals for any delays, ensuring accurate and synchronized operation across multiple cycles.

3. **Cycle Repetition Testing:**

- Run the shutter through multiple cycles (e.g., 100 cycles) to test consistency in performance and reliability.
- Document the system's response at each cycle and monitor for any signs of wear, latency, or system drift.

Step 3: Data Collection

- **Signal Accuracy:** Log signal timings and validate against expected values.
- **Power Stability:** Measure voltage output from the SMPS to check stability under operational loads.
- **Cylinder Position Accuracy:** Track the position of each cylinder after actuation to ensure it aligns with the target.

RESULTS AND DISCUSSIONS :

1. **Cycle Time Consistency:** The shutter consistently completed open and close cycles within the expected time frame (e.g., under 10 seconds per cycle), demonstrating reliable system performance.
2. **Signal Accuracy and System Responsiveness:** All PLC I/O signals were transmitted accurately to the relevant components, with no observed delays or errors.
3. **Power Stability from SMPS:** The Omron SMPS provided stable output, maintaining a consistent voltage and current, supporting uninterrupted operations.
4. **Pneumatic Cylinder and DCV Reliability:** The pneumatic cylinders and 5/3 DCVs functioned accurately, with each command resulting in the expected movement, whether extending or retracting the cylinders.

CONCLUSION:

The automatic shutter system utilizing PLC and barcode scanning technology offers a significant advancement in the automotive industry by automating component distribution based on vehicle models. This system enhances efficiency, reduces human error, and streamlines the production process. By ensuring accurate and timely access to the required components, the solution supports higher productivity, better quality control, and reduced operational costs. The successful implementation confirms that automation in component handling can improve overall manufacturing performance and adaptability in response to increasing product variability and customization.

FUTURE SCOPE OF THE WORK:

- **Integration with IoT and Remote Monitoring:**

The system could be upgraded with IoT capabilities, allowing remote monitoring and control. This would enable real-time tracking of system performance, cycle counts, and maintenance needs, enhancing operational efficiency and reducing downtime.

- **Enhanced Safety and Diagnostics:**

Adding sensors and diagnostic tools to detect malfunctions, track wear and tear, and predict maintenance needs would make the system safer and more reliable. Features like emergency stops and overload protection could also improve safety in industrial environments.

- **Automation and Control Optimization:**

Advanced PLC programming and control algorithms, such as adaptive timing adjustments based on load or operational conditions, could make the shutter more energy-efficient and responsive. This would also allow for smoother transitions and optimized cycle times.

- **Expansion to Multi-Mode Operation:**

The system could be enhanced to operate in multiple modes, such as adjustable speed settings or partially open positions, based on specific requirements. This flexibility would cater to various industry needs and reduce energy consumption in low-demand situations.

- **Enhanced Pneumatic Efficiency and Energy Savings:**

Exploring the use of variable-speed compressors and efficient pneumatic components could improve energy efficiency. Developing energy-saving strategies like low-power standby modes could reduce the overall energy footprint of the system.

- **Application in Diverse Industrial Sectors:**

With minor modifications, the system can be adapted for use in other industries beyond automotive, such as manufacturing, warehousing, or any environment requiring automatic doors or barriers. Customizable control logic would make the system versatile for various applications.

REFERENCES:

1. Shaik Roshan, Dr. M. Muthuvinayagam and S. Manivannan
2020 IoT
Based Remote Monitoring and Controlling for Shutter Systems,
International Journal of Trend in Scientific Research and
Development (2456 – 6470) Vol. 2
2. Minghai Yuan, Weijun Huang¹, Xiteng Zhang and Shumin Tian
2019 Design of welding control system based on Siemens PLC
3. S. Shiravale, P. Sriram, S-M. Bhagat, Flood Alert System by
using Weather Forecasting Data and Wireless Sensor Network,
International Journal of Computer Applications (0975 – 8887)
Vol.124, No.10, 2015.
4. Wu J 2011 Design of control system for automatic welding
production line of pump truck boom (Changsha: Hunan
University Press) p 41.
5. Zhao P F and Zhang B C 2009 Design and implementation of
S7200PLC human machine interface Mechanical Engineering
and Automation 135-136.
6. Li D Y and Chen G 2018 Design of control system for concrete
mixing plant based on PLC and touch screen Automation and
Instrumentation 33 1244-47.

10. AS AND FLAME EMERGENCY SHUTDOWN SYSTEM

Name of Student: Saeed Avinash Palekar

Komal Somnath Pingle
Sudhiksha Bhaskar Chavan

Year: B.E. _2024-2025

Title: Gas and Flame Emergency Shutdown System

Abstract:

In the oil and gas industry, safety, efficiency, and precision are critical. The Emergency Shutdown System plays a crucial role in preventing accidents, protecting equipment, and ensuring the safety of personnel. This paper discusses the implementation of an ESDS system using Programmable Logic Controllers to enhance operational control and automation in oil and gas processes.

The PLC-based ESDS monitors critical parameters such as pressure, temperature, and flow within pipelines, tanks, and processing equipment. When predefined unsafe conditions are detected, the system automatically triggers shutdowns to prevent catastrophic failures, leaks, or explosions. PLCs offer reliability, real-time monitoring, and flexibility, making them ideal for automating safety functions in such hazardous environments.

This system reduces human intervention and error, allowing for faster response times in emergencies. The integration of PLCs also enables remote monitoring and diagnostics, enhancing the ability to detect and respond to issues before they escalate. The use of modern communication protocols in PLCs ensures that the ESDS can interface with broader control systems, enabling seamless integration across various operational platforms.

In conclusion, the PLC-based ESDS system provides a robust, automated safety mechanism for the oil and gas industry, improving both safety and efficiency in managing critical operations.

INTRODUCTION:

1.1 Introduction of the Project Work

ESDS are mainly used in the oil and gas industries. The emergency shutdown system is used to control any kind of danger occurring in the industry. Various types of emergency shutdown valve are used for controlling the process. They can also be used for controlling the temperature, pressure and the level control in the tank. If the pressure increases above the set point the three can be danger so the ESDV closes the valve same as for the temperature and level. The whole process can be understood through the P&ID diagram. The highlighted parts in P&ID are in control of the manufacturing company that is us and the non- highlighted parts are on field and are controlled by the customer. Only the closing of the ESDV is done by us and the turning on operation is done by the oil and gas industry. The cause-and-effect matrix is use to analyze the control of the valves, and the transmitters of the temperature, pressure and level. The liquid used in the flow is the LPG. This project is overall about the operating and control strategy for the LPG facility.

1.2 Problem Statement

LPG storage and jetty operations are high-risk, with leaks, overpressure, or system failures posing serious safety hazards. Current manual or semi-automated systems may not respond quickly enough to emergencies, increasing the risk of accidents. A fully automated, reliable ESDS is urgently needed to detect hazards and trigger immediate shutdowns, ensuring safety for personnel and the environment.

1.3 Objectives

The objective of our project is to carry to Detailed Engineering Design of 15,00 MT LPG facility and jetty with design conformances with design specifications and industry standards. To enable automatic shutdown of operations in the event of hazardous conditions, minimizing human intervention.

1.4 Scope of the Project Work

The scope of the project includes:

- 1 Designing a PLC-based ESDS tailored for LPG storage tanks and jetty operations.
- 2 Installing sensors to detect critical parameters such as gas leaks, pressure, and temperature deviations.
- 3 Automating emergency shutdown processes to ensure quick responses during hazardous conditions.
- 4 Integrating the ESDS with existing HMI and control systems for real-time monitoring and diagnostics.
- 5 Conducting testing and simulations to ensure system reliability and performance under emergency conditions.
- 6 Providing operational guidelines and training for personnel to manage and maintain the system.

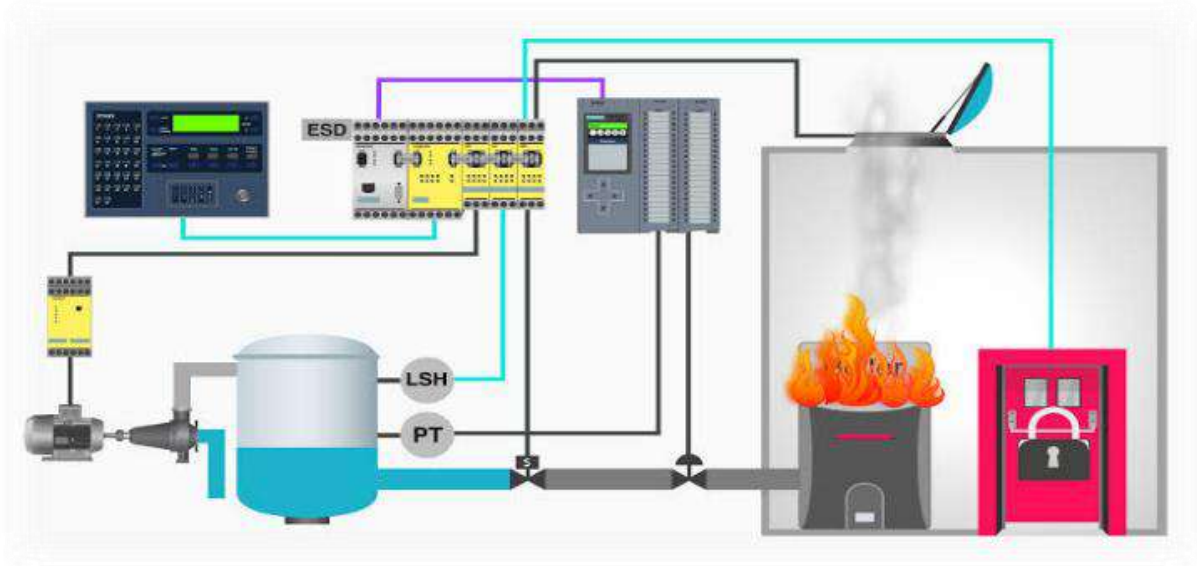

Figure 1. Gas and Flame ESDS

LITERATURE REVIEW:

An Emergency Shutdown System is an automated safety mechanism designed to detect hazardous conditions and trigger an immediate shutdown of operations in industries dealing with high-risk processes. It operates through Programmable Logic Controllers, which monitor critical parameters like pressure, temperature, and gas levels to prevent accidents. Regulatory Compliance: Many industries are required by law to implement ESDS systems to meet safety regulations.

METHODOLOGY:

The methodology below emphasizes the importance of a structured approach to safety in LPG storage within the oil and gas industry. By integrating detection, alarm systems, automated responses, and operator involvement, the ESDS enhances safety and minimizes risks associated with hazardous materials.

- **Detection:**

The system continuously monitors for hazardous conditions, such as leaks, pressure surges, or abnormal temperatures. Detection involves using various sensors and alarms to identify any anomalies.

- **Alarm Activation:**

Once a hazard is detected, an alarm is activated to alert operators and relevant personnel. This initial alert is crucial for raising awareness about potential dangers in the facility.

- **Control System Response:**

Following the alarm, the control system evaluates the situation and determines the appropriate response. This may involve adjusting system parameters or preparing for an emergency shut

About Project:

4.1 Components Used

4.1.1 Mounted on PLC

1. PLC Panel: A PLC panel is a special steel box that contains electrical components required to run a factory machine or process. It is the core brain controlling industrial equipment.

Make - Rittal Plc

Dimensions - 750(W)*1650(H)*400(D).



Figure 3. Rittal PLC Panel

2. End Plate: End Plates are used to cover the live parts of the last Terminal Block is used.

Make - Connectwell

Model type - DB TB and 4SQMM TB

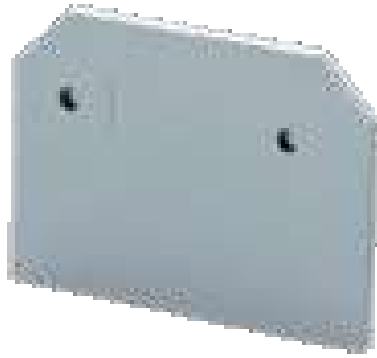

Figure 4. Endplate

3. Indication Lamp: Red indication lamps used. LED pilot lights visually indicate the status or condition of a device, process, or system. They can signal the on/off quality of equipment, the activation of a specific mode, the presence of a fault, the completion of a process, or any other relevant information.

Make - TEKNIC



Figure 5. Indication Lamp

4. Push Button: Here red and Emergency push buttons are used. It is used for high reliability and safety of equipment.

Make - TEKNIC



Figure 6. Push Buttons

5. Contacts: NO and NC contacts are where the states of switches under when their coil is de-energized.
Make – TEKNIC



Figure 7. NO and NC Contacts

6. Relays: A Relay is also a switch that connects or disconnects two circuits

Make – OMRON

Type – Slim relay with base



Figure 8. Slim relay with base

7. Tube light: Tube light makes the components visible inside the PLC.

Make – Standard



Figure 9 :Tube light

8. Fuse TB: Fuse terminal blocks, we accommodate fuses in different designs and with different nominal currents.

Make – Connectwell

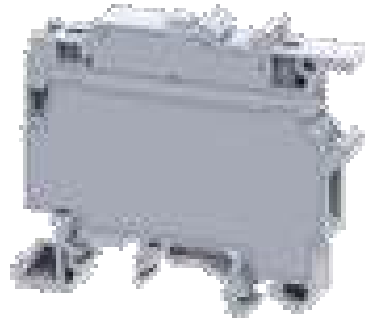

Figure 10 : Fuse TB

9. Door Limit Switch: Mechanical limit switches are contact sensing devices widely used for detecting the presence or position of objects in industrial applications.

Make – Standard



Figure 11 : Door limit Switch

10. SMPS: Switched Mode Power Supply is designed to provide the energy to load from source by using switching devices.

Make – OMRON

Voltage - 24 volts DC

Current – 10A



Figure 12 : SMPS

11. MCB: A Miniature Circuit Breaker is a type of electrical protection device used to automatically switch off an electrical circuit in case of an over-current, overvoltage, or short circuit.

a) Make – SIEMENS

Pole – Single

Current – 4A

Breaking capacity – 10KA



Figure 13 :MCB 1P

b) Make – SIEMENS

Pole – Two

Current – 25A, 6A, 210A

Breaking capacity – 10KA



Figure 14 : MCB 2P

12. Diode TB: A diode is an electrical device allowing current to move through it in one direction with far greater ease than in the other
Make – Connectwell



Figure 15 : Diode TB

13. Selector Switch: A mechanical switch that can be rotated right, left, or center to open or close the electrical contacts is known as a selector switch.
Make – TEKNIC



Figure 16 : Selector Switch

14. Ethernet Switch: An Ethernet switch is a type of network hardware that is foundational to networking and the internet.
Make – TELTONIKA



Figure 17 : Ethernet Switch

15. Ethernet Technology: In PLCs, Ethernet Technology enables real-time communication and data exchange between the PLC and other devices over a network.
a) Make – SIEMENS
Model – ET 200 SP
Module – Digital Output
Output channels - 16
Voltage – 24 volts DC
Product line - PU1



Figure ET 16*24V

b) Make – SIEMENS

Model – ET 200 SP

Module – Digital Output

Output channels – 8

Maximum Current output – 0.5 A

Voltage – 24 volts DC

Product line - PU1



Figure ET 8*24V

16. Communication Module: A communication module is a device or component that enables data exchange between different systems, devices, or networks, facilitating interoperability and connectivity in automation and control applications.

Make - SIEMENS

Serial Communication Standards - RS-232, RS-422, and RS-485



Figure Communication Module

17. HMI: A graphical user interface that can be controlled with a mouse or touchscreen.

Make – SIEMENS

Model type – HMI

Series – 1500



Figure HMI

18. CPU: CPU is the actual brain of the PLC, making it a computer.

Make - SIEMENS

PN -1512SP-1

Programming Memory – 200KB Prog.

Data memory – 1MB



Figure CPU

19. Memory Card: The memory card allows you to keep a copy of your project on the controller without the need to maintain power to the controller.

For PLC,

Make - SIEMENS

PN - SIMATIC S7

Storage - 12MB



Figure Memory Card (PLC)

For HMI,
Make – SIEMENS
PN - SIMATIC SD
Storage – 2GB



Abbildung ähnlich

Figure Memory Card (HMI)

20. End clamp Stopper: End stops are essential safety components.
21. PLC: Siemens Plc used these are the miniature industrial computers that contain hardware and software used to perform control functions

4.1.2 Sensors

1. A radar type Level Transmitter (LI-102): The LI-102 is a radar-type level transmitter that uses microwave signals to accurately measure the level of liquids or solids in various industrial applications, providing continuous, noncontact level measurement



Figure radar type level transmitter

2. Temperature Transmitter (TT-102): The TT-102 is a temperature transmitter designed to convert temperature sensor signals into standardized output signals, enabling accurate temperature monitoring and control in industrial processes.



Figure Temperature Transmitter

3. Pressure Transmitter (PT-102): The PT-102 is a pressure transmitter that converts pressure measurements into standardized electrical signals for monitoring and controlling pressure levels in various industrial applications.



Figure Pressure Transmitter

4.1.2.1 Output

1. Fire And Gas Detection:

- a) Optical type smoke detectors: Optical type smoke detectors use a light source and sensor to detect the presence of smoke particles in the air, providing early warning of potential fire hazards in various environments.



Figure Smoke detectors

- b) Ultraviolet or Infra-red type flame detectors: Ultraviolet or infrared type flame detectors identify the presence of flames by sensing the specific wavelengths of light emitted during combustion, providing rapid detection of fire in hazardous environments.



Figure Flame Detector

- c) Manual Alarm Call Point (MACP): A manual alarm call point is a safety device that allows individuals to manually trigger an alarm in case of fire or gas detection, ensuring prompt notification to alert occupants and initiate emergency response.



Figure MACP

4.2 Results and Application Mod



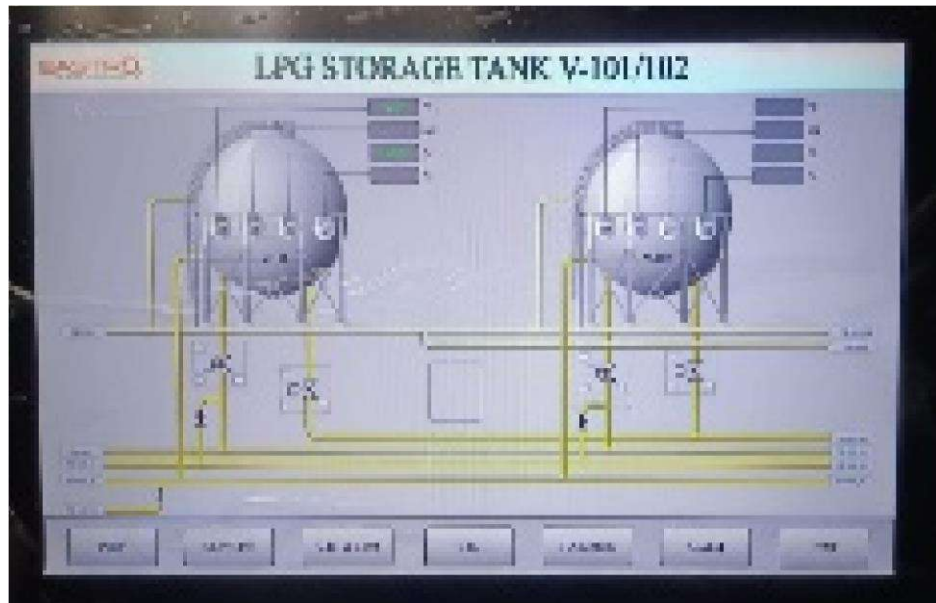

Figure. Analysis and Monitoring of ESDS with the help of Graphs





Figure Final Gas and flame Control Panel



Figure Final water pump Control Panel

CASE STUDY

The Bhopal Gas Tragedy of 1984 remains one of the deadliest industrial accidents in history, caused by the release of methyl isocyanate (MIC) gas from Union Carbide's pesticide plant. Over 40 tons of toxic gas leaked, killing thousands and affecting many more due to serious safety lapses.



One critical issue was the absence of a functional Emergency Shutdown System that could have

detected and mitigated the rising pressure inside the Figure. Bhopal Gas Tragedy MIC tank. One of the main lines of argument involving the disaster was Corporate Negligence. Multiple safety mechanisms, like the vent scrubbers and flare tower, which should have neutralized the gas, were either faulty or turned off. Additionally, there was no real-time monitoring system to detect the rapid increase in temperature and pressure inside the tank.

A robust PLC-based ESDS could have played a pivotal role by:

- Monitoring critical parameters such as temperature and pressure.
- Triggering automatic shutdowns when unsafe conditions, like overpressure, were detected.
- Activating safety systems like the vent scrubber and flare tower to contain the gas leak. The plant relied heavily on manual intervention, and due to the rapid escalation of the crisis, workers were unable to respond in time. A properly functioning ESDS could have isolated the tank and stopped operations, potentially preventing the gas from escaping.

ESDS in Hazardous Industries:

1. Real-Time Monitoring: Continuous monitoring of critical parameters can detect early signs of failure.
2. Automated Shutdown: A well-designed ESDS can instantly respond to unsafe conditions, reducing reliance on human intervention.
3. System Maintenance: Regular testing and maintenance of safety equipment are essential to ensure readiness in emergencies.

In conclusion, the tragedy emphasizes the need for automated, reliable ESDS systems to prevent such disasters in high-risk industries like oil, gas, and chemicals, where fast and automatic responses are vital to saving lives and protecting the environment.

CONCLUSION:

1. The project focuses on the Detailed Engineering Design of a 15,000 MT LPG facility and jetty.
2. The design will conform to relevant design specifications and industry standards.
3. A key objective is to implement systems that enable automatic shutdown of operations during hazardous conditions.
4. The system will be designed to minimize human intervention, ensuring enhanced safety and operational efficiency.

7.2 Future scope of the work

1. **System Expansion and Upgrades:** The PLC-based ESDS can be expanded to include additional safety features, such as real-time data analytics, predictive maintenance, and integration with AI for advanced hazard detection.
2. **Integration with IoT:** Future developments can integrate IoT sensors to enable remote monitoring of LPG storage and jetty operations, allowing for faster response times and better data-driven decision-making.
3. **Energy-Efficient Solutions:** Research and development can focus on making the ESDS more energy-efficient, reducing power consumption during continuous monitoring and operation.
4. **Global Standardization:** The system can be adapted to meet evolving global safety standards and regulations in the oil and gas industry, ensuring international compliance.
5. **Automation in Other Areas:** The success of this ESDS could lead to further automation across other oil and gas operations, including upstream, midstream, and downstream sectors, enhancing safety throughout the industry.

Future Scope of Work in the Oil and Gas Industry: -

1. **System Expansion:** The PLC-based ESDS can be expanded to cover additional areas within the oil and gas industry, such as refineries and pipeline operations, improving overall safety.

2. IoT Integration: Incorporating IoT sensors for remote monitoring and real-time control of operations, leading to faster emergency response and enhanced operational efficiency.
3. Advanced Automation: Expanding automation in areas like drilling rigs, refinery units, and transportation, further reducing human intervention and increasing safety.
4. Global Compliance: Adapting the ESDS to meet international safety standards and environmental regulations, ensuring the system is applicable across global oil and gas operations.
5. Energy Efficiency: Focusing on developing energy-efficient safety systems to reduce the environmental impact of continuous monitoring and emergency operations in the oil and gas sector.
6. AI-Driven Safety: Integrating AI and machine learning for predictive maintenance and advanced hazard detection, ensuring proactive management of potential risks.

REFERENCES:

- [1] <https://www.teknic.co.in>
- [2] <https://www.ia.omron.com/products/category/sensors/>
- [3] https://www.google.com/url?sa=t&source=web&rct=j&opi=89978449&url=https://www.onnectwell.com/&ved=2ahUKEwj0h5XzqaeJAxXo1TQHHTpLCGEQFnoECAkQAQ&usg=AOvVaw_0G8kp7upwpj_GqFh9JkoZX
- [4] "Design and Implementation of Emergency Shutdown System for Oil and Gas Facilities" (IEEE, 2019)
- [5] "Gas and Flame Detection Systems for Emergency Shutdown Applications" (Journal of Loss Prevention in the Process Industries, 2018)
- [6] "Evaluation of Emergency Shutdown Systems for Chemical Process Industries" (Process Safety Progress, 2018)
- [7] "Reliability Analysis of Emergency Shutdown Systems in Oil and Gas Industry" (International Journal of Reliability, Quality and Safety Engineering, 2020)

Instru Tech

TECHNICAL MAGAZINE COMMITTEEMEMBERS

Dr. B. J. Parvat	H.O.D. (Instru & Control)
Mr. S. D. Nikam	Editor in Chief
Mr. S. R. Patil	Co-Editor Staff Coordinator
Mr. Pranav S. Patil	Student Co Editor Coordinator
Ms. Sae A. Palekar	Student Co Editor Coordinator
Ms. Revati S. Patil	Student Coordinator
Mr. Sujit R. Gadhe	Student Coordinator
Mr. Akash G. Pole	Student Coordinator
Mr. Harsh M. Chaudhari	Student Coordinator
Mr. Kunal H. Fegade	Student Coordinator

Website:www.kbtcoe.org
Email : hod.instru@kbtcoe.org